

HI-LOK/HI-SHEAR TYPE AIR DRIVERS

PISTOL DRIVER, 2 INCH OFFSET OMP110

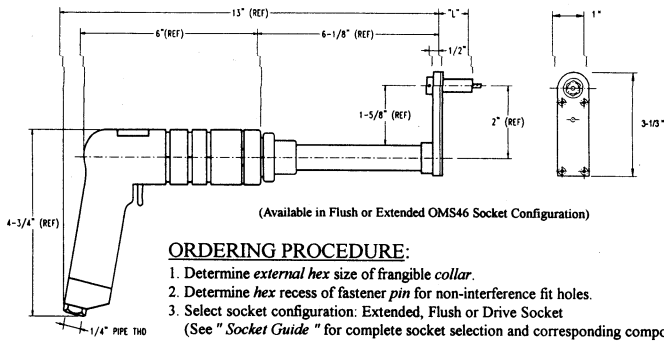

(Available in Flush or Extended OMS46 Socket Configuration)

ORDERING PROCEDURE:

1. Determine external hex size of frangible collar.
2. Determine hex recess of fastener pin for non-interference fit holes.
3. Select socket configuration: Extended, Flush or Drive Socket (See "Socket Guide" for complete socket selection and corresponding components.)
4. Complete part number as shown below:

Example: **OMP110-2106E**

Socket Part Number Selected from Socket Guide
7/32 (.21) Socket Hex Recess, 1/16 (.06) Hex Key,
E= .75 Socket Length

Basic Model Number of Complete Tool Assembly

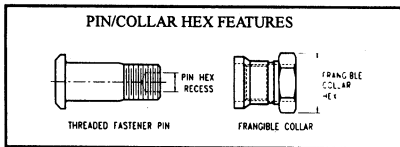

Made in U.S.A.

TECHNICAL DATA

Operating Pressure.....90 psia
MAXIMUM TORQUE RATING.....270 in lbs
(motor) at 90 psia
Motor Speed.....600 rpm
Air Consumption.....25 cfm
Weight.....3.0 lbs.

PISTOL DRIVER, INLINE OMP160

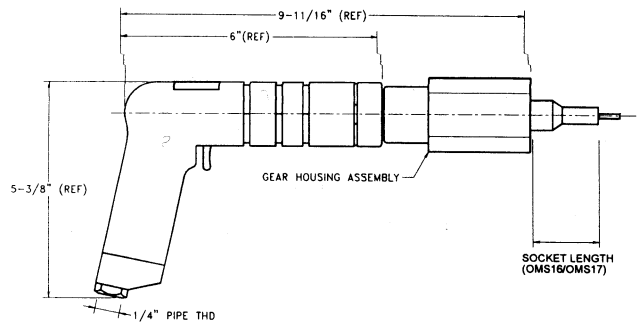

ORDERING PROCEDURE:

1. Determine external hex size of frangible collar.
2. Determine hex recess of fastener pin for non-interference fit holes.
3. Select socket configuration (See "Socket Guide" for complete socket selection and corresponding components.)
4. Complete part number as shown below:

Example: **OMP160-2106E**

Socket Part Number Selected from Socket Guide
7/32 (.21) Socket Hex Recess, 1/16 (.06) Hex Key
E=.75 Socket Length

Basic Model Number of Complete Tool Assembly

RATCHET WRENCH, STRAIGHT OMW212

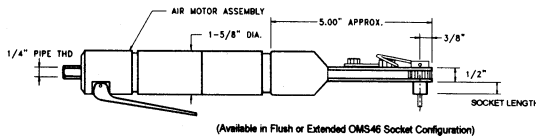

(Available in Flush or Extended OMS46 Socket Configuration)

SOCKET ASSEMBLY, EXTENDED OMS46

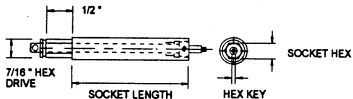

1. For use with OMP110, OMW212, and OMW251 drivers.
2. Match external hex size of frangible collar in column A.
3. Match hex recess of fastener pin in column B.
4. Select socket length as follows:

E=.75 inch, B=1.00 inch, D=2.00 inch

5. Combine part numbers as listed in chart.

Example: **OMS46-2106E**
E= .75 inch long socket
1/16 (.06) inch hex key
7/32 (.21) inch external collar hex drive
Model Number

A	B	SOCKET LENGTH		
		(E=.75" lg.)	(B=1.00" lg.)	(D=2.0" lg.)
7/32	1/16	OMS46-2106E	OMS46-2106B	OMS46-2106D
1/4	1/16	OMS46-2506E	OMS46-2506B	OMS46-2506D
9/32	1/16	OMS46-2806E	OMS46-2806B	OMS46-2806D
5/16	1/16	OMS46-3106E	OMS46-3106B	OMS46-3106D
11/32	1/16	OMS46-3406E	OMS46-3406B	OMS46-3406D
7/32	5/64	OMS46-2107E	OMS46-2107B	OMS46-2107D
1/4	5/64	OMS46-2106E	OMS46-2106B	OMS46-2106D
9/32	5/64	OMS46-2807E	OMS46-2807B	OMS46-2807D
5/16	5/64	OMS46-3107E	OMS46-3107B	OMS46-3107D
11/32	5/64	OMS46-3407E	OMS46-3407B	OMS46-3407D
3/8	5/64	OMS46-3707E	OMS46-3707B	OMS46-3707D
5/16	3/32	OMS46-3109E	OMS46-3109B	OMS46-3109D
11/32	3/32	OMS46-3409E	OMS46-3409B	OMS46-3409D
3/8	3/32	OMS46-3709E	OMS46-3709B	OMS46-3709D
7/16	3/32	OMS46-4309E	OMS46-4309B	OMS46-4309D
3/8	1/8	OMS46-3712E	OMS46-3712B	OMS46-3712D
7/16	1/8	OMS46-4312E	OMS46-4312B	OMS46-4312D

SOCKET ASSEMBLY, 2 INCH LONG OMS16

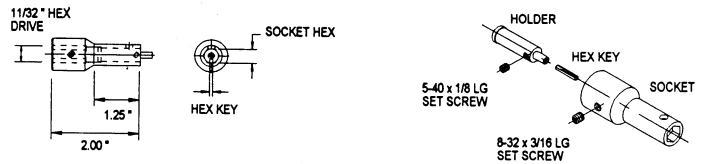

1. For use with OMP160 Pistol Driver. (See "Socket Guide")
2. Match external hex size of frangible collar in column A.
3. Match hex recess of fastener pin in column B.
4. Combine part numbers as listed in column C. (See example)

Example: **OMS16-2106**

1/16 (.06) inch pin hex recess
7/32 (.21) inch external collar hex drive
Model Number (2 inch long socket)

A	B	C
7/32	1/16	OMS16-2106
1/4	1/16	OMS16-2506
9/32	1/16	OMS16-2806
5/16	1/16	OMS16-3106
11/32	1/16	OMS16-3406
7/32	5/64	OMS16-2107
1/4	5/64	OMS16-2507
9/32	5/64	OMS16-2807
5/16	5/64	OMS16-3107
11/32	5/64	OMS16-3407
3/8	5/64	OMS16-3707
5/16	3/32	OMS16-3109
11/32	3/32	OMS16-3409
3/8	3/32	OMS16-3709
7/16	3/32	OMS16-4309
3/8	1/8	OMS16-3712
7/16	1/8	OMS16-4312

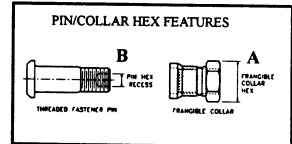

RATCHET WRENCH, 20° OFFSET OMW251

