

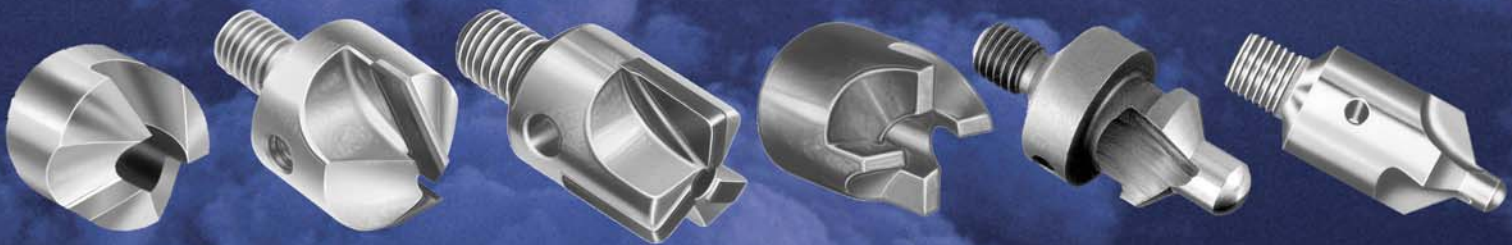

CRAIG TOOLS  
INTERNATIONAL  
ROTARY CUTTING TOOLS FOR THE AEROSPACE INDUSTRY



ISO 9001:2000 CERTIFIED



# CRAIG TOOLS INTERNATIONAL

ROTARY CUTTING TOOLS FOR THE AEROSPACE INDUSTRY

---

*Founded in 1958, Craig Tools International has become a significant supplier of rotary cutting tools to the airframe industry as well as automotive, machine tool and job shop environments.*

*We have maintained our special cutting tool roots while becoming a volume producer with our own standard catalog line focused around the needs of the airframe world. At any given time the bulk of our production is tooling made to customer print specifications.*







*We are a prime source of "micro stop" tooling for the major airframe builders and repair and maintenance facilities around the world. Our product line includes high speed steel, cobalt steel, carbide and polycrystalline diamond cutting tools as well as a variety of hole preparation and fastener installation tools and equipment.*

*To meet the rapidly changing world of materials technology in all manufacturing segments we have a well-equipped and responsive engineering department with research and development capability to address these difficult applications. We continue to invest in increased polycrystalline diamond (PCD) capability along these lines.*

*As we grow to meet the needs of the global economy and the ever-changing manufacturing techniques of the 21<sup>st</sup> century, it is our sincere desire that you, our customer, have a positive and productive experience when partnering with Craig Tools International.*

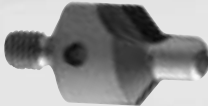

# CONTENTS

<b>SOLID CARBIDE COMPOSITE CUTTING TOOLS</b>		4	
<b>METRIC STOP COUNTERSINKS</b>	Carbide Tipped, PCD, Cobalt, High Speed Steel and Pilots	5, 6, 7, 8	
<b>MICROSTOP COUNTERSINK UNITS</b>		9	
<b>STRAIGHT SHANK COUNTERSINKS</b>		10	
<b>PCD CUTTERS</b>	Integral Pilot, Removable Pilot	11	
<b>VERSI SINKS</b>	Bodies, Pilots, Inserts	12, 13	
<b>STOP COUNTERSINKS</b>	High Speed Steel, Carbide Tipped, Solid Carbide	14, 15, 16	
<b>STOP COUNTERBORES</b>		17	
<b>COUNTERSINK PILOTS</b>		18	
<b>ANGLE DRILLS, COLLET CHUCKS</b>		19	
<b>AIRCRAFT COUNTERBORES, HOLLOW CUTTERS</b>	High Speed Steel	20	
<b>AIRCRAFT COUNTERBORES</b>	Carbide Tipped	21	
<b>COUNTERBORE PILOTS</b>		22	
<b>HOLE SAWS, ARBORS</b>	Coarse, Fine Tooth and Arbors	23	

# CONTENTS



**REVERSE COUNTERSINKS** High Speed Steel, Carbide 24, 25



**REVERSE SPOTFACERS** High Speed Steel, Carbide 26, 27

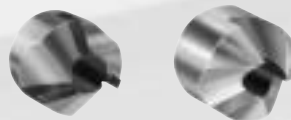

**REVERSE CUTTER PILOTS** 28



**RIVET SETS** Cupped, Flush, Offset 29 – 36



**SQUEEZER SETS** Cupped, Flush 37, 38



**DIMPLING TOOLS, RETAINER SPRINGS** 39



**LONG SERIES AIRCRAFT COUNTERBORES** 40



**BURRING CUTTER, EXTENSIONS, SPEED DRIVER** 41

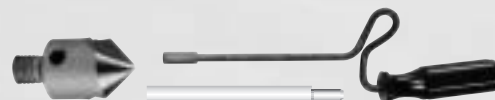

**DRILLS AND REAMERS** Extension, Threaded Shank, Piloted 42



**DRILL ADAPTERS, DUPLICATING PUNCHES** 43



**RIVET TOOLS** Hand Squeezer, Retainer Spring, Rivet Gun, Clecos, Pliers, Drill Stops 44, 45

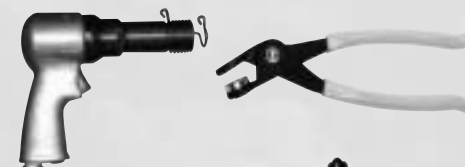

**STRAP DUPLICATORS** Spring, Bushing, Bushing Inverted 46



**PORT CONTOUR CUTTERS—A.N.D. 10050 AND MS33649, S.A.E. (MS 16142)** High Speed Steel, Carbide Tipped 47 – 54





# CARBIDE TOOLS

**FOR ADVANCED COMPOSITES**  
(MADE TO YOUR SPECIFICATIONS)



"Dagger" Drill



Parabolic Fluted Drill



Spacematic Drill Countersink



Tapered Drill-Reamer



Drivematic Drill Countersink



8 Facet Drill For Graphite



Nut-Plate Drill-Reamer



Fiberglass Router



1/4-28 Hex Adapted Drill



Router For Graphite



# M700 SERIES



**CARBIDE TIPPED STOP COUNTERSINKS  
REPLACEABLE PILOT THREADED SHANK**

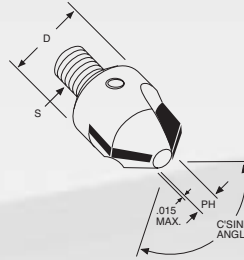

**FRAISE AU CARBURE À BUTÉE RAPPORTÉE  
GUIDE REMPLAÇABLE À TIGE FILETÉE**

**HARTMETALLBESTÜCKTE ANSCHLAGSENKER  
AUSTAUSCHBARER FÜHRUNGSZAPFEN, GEWINDESCHAFT**

**AVELLANADORAS DE TOPE CON PUNTA DE  
CARBUROPILOTO REEMPLAZABLE, ESPIGA ROSCADA**

**M700 SERIES** carbide countersink cutters excel in cutting highly abrasive materials, and are recommended for countersinking the "difficult to machine" and "exotic" materials.

Replaceable pilot for the substitution of various pilot diameters. (For pilot information see the M755 Series.) Maximum non-cutting diameters is .8mm (1/32 ") larger than the pilot hole. We recommend using cutters with pilot holes .8mm (1/32 ") minimum smaller than the desired pilot diameter, see sketch. 100° angle is stocked. Other angle, available.

Les fraises au carbure **SÉRIE M700** excellent dans la coupe de matériaux hautement abrasifs et sont recommandées pour fraiser les matériaux « difficiles à usiner » et « exotiques ».

Le guide remplaçable permet la substitution de guides de diamètres variés. (Pour plus d'informations sur les guides, voir la Série M755). Le jeu fonctionnel sans enlèvement de copeaux est d'un diamètre supérieur de 0,8 mm (1/32 po.) à celui du trou du guide. Nous recommandons l'utilisation de fraises avec des trous de guide inférieurs de 0,8 mm (1/32 po.) au diamètre souhaité du guide. Voir croquis. L'angle de 100° est disponible en stock. D'autres angles sont disponibles.

Die Hartmetall-Senker der **M700 SERIES** zeichnen sich durch die Fähigkeit aus, hochabrasive Materialien zu schneiden, und werden zur Senkung „schwer bearbeitbarer“ und „exotischer“ Materialien empfohlen.

Austauschbare Zapfen für Substitution verschiedener Zapfendurchmesser. (Für Informationen zum Führungszapfen siehe M755 Series.) Der maximale spanlose Durchmesser ist 0,8 mm (1/32 Zoll) größer als die Vorbohrung. Wir empfehlen die Verwendung von Senkern mit Vorbohrungen, deren Durchmesser mindestens 0,8 mm (1/32 Zoll) kleiner ist als der gewünschte Vorbohrungsdurchmesser (siehe Zeichnung). 100°-Winkel lieferbar. Andere Winkel ebenfalls erhältlich.

**SERIE M700:** avellanadoras de carburo excelentes para fresar materiales muy abrasivos; se recomiendan para avellanar materiales "exóticos" y "difíciles de maquinar".

Piloto reemplazable para sustituir varios diámetros de pilotos. (Consultar la Serie M755 para obtener información sobre los pilotos.) El diámetro no cortante máximo es 0,8 mm (1/32 pulg.) más grande que el orificio del piloto. Recomendamos utilizar fresas con orificios de piloto de por lo menos 0.8 mm (1/32 pulg.) más pequeños que el diámetro del piloto deseado; consultar el diagrama. La unidad de ángulo de 100° se mantiene en existencias. Otros ángulos disponibles.

M700 SERIES				
TOOL NUMBER	"D" BODY DIA.	"PH" PILOT HOLE	NUMBER OF FLUTES	"S" SHANK SIZE
M700	10	2.00	2	6 X 100
M702	14	2.00	2	8 X 100
M703	14	2.50	2	8 X 100
M704	14	3.50	2	8 X 100
M705	17	3.50	2	8 X 100



# M700 PCD SERIES

**POLYCRYSTALLINE DIAMOND TIPPED STOP COUNTERSINK  
REPLACEABLE PILOT, THREADED SHANK**



**PKD (POLYKRISTALLINDIAMANT)-BESTÜCKTER ANSCHLAGSENKER  
AUSTAUSCHBARER FÜHRUNGZAPFEN, GEWINDESCHAFT**

**M700 PCD SERIES** cutters excel in cutting highly abrasive non-ferrous materials in which carbide will not perform satisfactorily, such as graphite epoxy. A high clearance angle with identical lip height results in chatter free, highly economical hole production.

Replaceable pilot construction allows economical replacement of damaged pilots and substitution of various pilot diameters with the same cutter. (For pilot information see the M755 and 755 Series.) Maximum non-cutting diameters is .8mm (1/32 ") larger than the pilot hole. See sketch.

Die Senker der **M700 PCD SERIES** zeichnen sich durch die Fähigkeit aus, hochabrasive Nichteisenmetalle zu schneiden, bei denen Hartmetall (Karbid) keine zufriedenstellende Leistung zeigt (z.B. Graphite Epoxy). Der große Anstellwinkel mit identischer Schneidlippenhöhe ermöglicht eine ratterfreie, hochrationelle Bohrungsherstellung.

Die austauschbare Zapfenkonstruktion ermöglicht den kostengünstigen Austausch beschädigter Führungszapfen und die Substitution verschiedener Zapfendurchmesser im gleichen Senker. (Für Informationen zum Führungszapfen siehe M755 und 755 Series) Der maximale spanlose Durchmesser ist 0,8 mm (1/32 Zoll) größer als die Vorbohrung. Siehe Zeichnung.

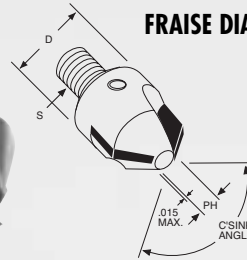

**FRAISE DIAMANT POLYCRISTALLINE À BUTÉE RAPPORTÉE  
GUIDE REMPLAÇABLE À TIGE FILETÉE**

**AVELLANADORAS DE TOPE CON PUNTA DE DIAMANTE  
POLICRISTALINOPILOTO REEMPLAZABLE, ESPIGA ROSCADA**

Les fraises **SÉRIE M700 PCD** excellent dans la coupe de matériaux non ferreux hautement abrasifs, notamment le graphite époxyde, pour lesquels le carbure est moins adapté. Un angle de dégagement élevé avec hauteur de lèvre de coupe identique permet une production très économique de trous sans broutage de l'outil.

La conception avec guide remplaçable permet le remplacement à moindre coût des guides endommagés et la substitution de guides de diamètres variés avec une même fraise. (Pour plus d'informations sur les guides, voir les Séries M755 et 755). Le jeu fonctionnel maximum sans enlèvement de copeaux est d'un diamètre supérieur de 0,8 mm (1/32 po.) à celui du trou du guide. Voir croquis.

**SERIE M700 PCD:** excelentes para materiales no ferrosos muy abrasivos en los cuales el carburo no rinde satisfactoriamente, como por ejemplo los compuestos de grafito-epoxi. Un ángulo de incidencia amplia con idéntica altura del reborde produce orificios muy económicos y sin chasquido.

La construcción con piloto reemplazable permite cambiar económicamente los pilotos dañados y sustituir varios diámetros de pilotos con la misma fresa. (Consultar las Series M755 y 755 para obtener información sobre los pilotos.) El diámetro no cortante máximo es 0,8 mm (1/32 pulg.) más grande que el orificio del piloto. Ver el diagrama.

M700 PCD SERIES					
TOOL NUMBER	"D" BODY DIA.	"PH" PILOT HOLE	NUMBER OF FLUTES	"S" SHANK SIZE	C'SINK ANGLE
M700 PCD	10	2	2	6 X 100	100"/130"
M703 PCD	14	2.5	2	8 X 100	100"/130"

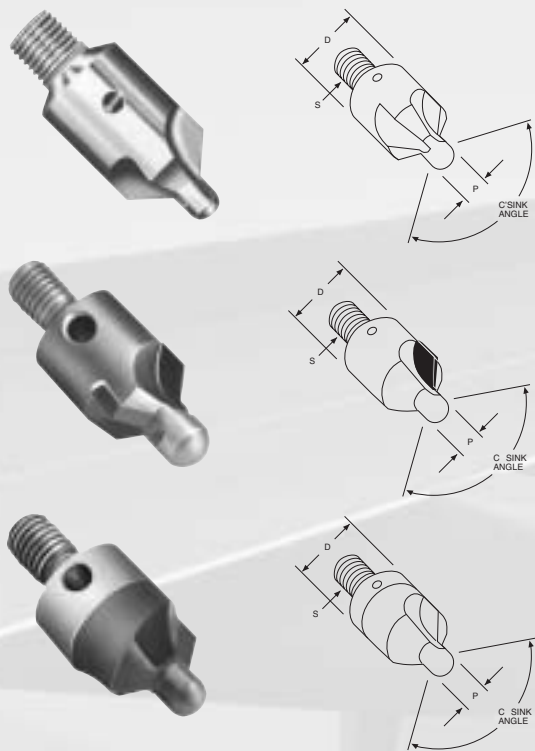

M150 SERIES			
TOOL NUMBER	"D" BODY DIA	"S" SHANK SIZE	PILOT RANGE
M150	10	6 X 1	2.38 - 4.83
COBALT STEEL	M152	14	8 X 1
	M153	17	8 X 1
	M155	21	8 X 1
SOLID CARBIDE	M152 SC	14	8 X 1
	M153 SC	17	8 X 1
	M155 SC	21	8 X 1
CARBIDE TIPPED	M152 CT	14	8 X 1
	M153 CT	17	8 X 1
	M155 CT	21	8 X 1

## INTEGRAL PILOT, THREADED SHANK

## GUIDE INTÉGRÉ À TIGE FILETÉE

## INTEGRIERTER FÜHRUNGSZAPFEN, GEWINDESCHAFT

## PILOTO INTEGRAL, ESPIGA ROSCADA

**M150 SERIES** countersink cutters in cobalt steel, carbide tipped & solid carbide may be used in all popular adjustable-stop or micro-stop type countersinking units utilizing a threaded shank drive. Made from the finest materials, with exacting tolerances and form relieved to insure concentricity of countersink angle, pilot and seat angle. Special sizes given prompt attention.

Die Senker der **M150 SERIES** aus Kobaltstahl, mit Hartmetallbestückung und Massivhartmetall, können in allen häufig verwendeten Senkereinheiten mit einstellbarem Anschlag oder vom Micro-Stop-Typ (Senkansschlag) verwendet werden, die einen Antrieb mit Gewindeschaf verwenden. Aus feinsten Materialien hergestellt, mit genausten Toleranzen und hinterdreht zur Sicherstellung der Konzentrität des Senkwinkels, Führungszapfen- und Anlagewinkels. Spezialgrößen werden umgehend bearbeitet.

Les fraises **SÉRIE M150** en acier au cobalt, au carbure et carbure monobloc, peuvent être utilisées sur toutes les unités de fraisage à butée réglable standard ou de type micro-butée utilisant un entraînement de guide à tige filetée. Nos fraises sont fabriquées dans les meilleurs matériaux, avec des tolérances rigoureuses et à profil constant afin d'assurer la concentricité de l'angle de fraisage, du guide et de la portée angulaire. Les fraises de dimensions particulières feront l'objet de notre attention dans les plus brefs délais.

**SERIE M150:** avellanadoras de acero al cobalto, con punta de carburo y carburo sólido que se pueden usar en todas las unidades populares de tope ajustable o microtope que utilizan una transmisión de espiga roscada. Fabricadas con los mejores materiales, con tolerancias exactas y diseños en relieve para garantizar la concentricidad del ángulo de avellanado, del piloto y del ángulo de asiento. Los pedidos de tamaños especiales se atienden con prontitud.





# M755 SERIES

PILOTS FOR REPLACEABLE PILOT STOP COUNTERSINKS

GUIDES POUR FRAISE À BUTÉE À GUIDE REMPLAÇABLE

FÜHRUNGSZAPFEN FÜR ANSCHLAGSENKER MIT AUSWECHSELBAREM FÜHRUNGSZAPFEN

PILOTOS PARA AVELLANADORAS DE TOPE CON PILOTO REEMPLAZABLE

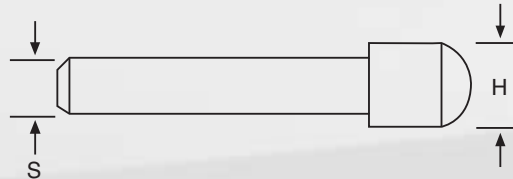

**M755 SERIES** pilots are made from the finest quality tool steel, heat treated and precision ground to exacting size and concentricity tolerances.

Les guides de la **SÉRIE M755** sont réalisés dans un acier de la meilleure qualité, avec traitement thermique dans la masse, et rectifiés à des cotes et tolérances de concentricité rigoureuses.

Die Führungszapfen der **M755 SERIES** sind aus wärmebehandeltem Werkzeugstahl feinsten Qualität hergestellt und sind auf die genaue Größe und Rundlauf toleranzen präzisionsgeschliffen.

**SERIE M755:** los pilotos de fabrican en acero para herramientas de la más alta calidad, se someten a tratamiento térmico y se pulen con precisión al tamaño exacto y tolerancias de concentricidad.

M755 SERIES METRIC PILOTS					
TOOL NUMBER	PILOT HEAD BODY DIA.	STANDARD SHANK DIAMETERS			
		2.00	2.50	3.50	5.00
M755-A	2.38	•			
M755-B	2.50	•			
M755-C	3.00	•	•		
M755-1	3.17	•	•		
M755-2	3.25	•	•		
M755-3	4.00	•	•	•	
M755-4	4.07	•	•	•	
M755-5	4.76	•	•	•	
M755-6	4.83	•	•	•	
M755-7	5.00	•	•	•	
M755-8	5.60	•	•	•	
M755-9	6.00	•	•	•	
M755-10	6.35	•	•	•	•
M755-11	6.50		•	•	•
M755-12	7.00			•	•
M755-13	7.80			•	•
M755-14	7.92			•	•
M755-15	8.00				•
M755-16	9.52				•
M755-17	10.00				•
M755-18	11.11				•
M755-19	12.00				•
M755-20	12.70				•
M755-21	15.87				•



**MICROSTOP** units feature hardened and ground spindles supported by either bronze bearings for general use or ball bearings for higher speed applications. Thrust bearings are used to insure depth stop accuracy while the micro adjustment allows for precise depth control.

**MICROSTOP** Einheiten zeichnen sich durch gehärtete und geschliffene Spindeln aus, die entweder durch Bronzelager für allgemeine Anwendungen oder Kugellager für Anwendungen mit höheren Geschwindigkeiten gehalten werden. Drucklager werden verwendet, um die Genauigkeit des Tiefenanslags sicherzustellen, während die MikroEinstellung die präzise Tiefenkontrolle ermöglicht.

Les unités à **MICROBUTÉE** sont dotées de broches durcies et rectifiées montées sur des roulements en bronze pour un usage général, ou sur roulements à billes pour des applications nécessitant une plus haute vitesse. Les paliers de butée servent à assurer la précision de la butée de profondeur alors que le micro-réglage permet un contrôle précis de la profondeur.

**MICROTOPE:** unidades que incluyen husillos endurecidos y pulidos apoyados por cojinetes de bronce para uso general o rodamientos para aplicaciones de más alta velocidad. Se utilizan cojinetes de empuje para asegurar la exactitud de la profundidad del tope, mientras que el microajuste permite un control preciso de la profundidad.



BE376/BE350



BE576/BE560



BE650

MODEL NUMBER	CUTTER CAPACITY*	SHAFT TRAVEL	SHAFT THREAD	MAX. RPM
BE376	11	6	6 X 1	3000
BE576 †	16	8	6 X 1	3000
BE578 †	21	8	8 X 1	3000
BE586 ††	21	8	6 X 1	10000
BE350	7/16	1/4	1/4-28	3000
BE560 †	5/8	5/16	1/4-28	3000
BE565 †	5/8	5/16	1/4-28	10000
BE566 ††	5/8	5/16	1/4-28	10000
BE650 †	1	1/2	3/8-24	3000
BE655 †	1-1/4	1/2	3/8-24	3000

\* Maximum with standard skirt,

† Dual bearings for upper and lower spindle support.

†† Sealed ball bearing unit.

NOTE: THESE UNITS ARE AVAILABLE WITH SCREW ON (REPLACEABLE) FOOT PIECES. PLEASE SPECIFY TYPES AND SIZES REQUIRED.



# 350 SERIES

## STRAIGHT SHANK PILOTED COUNTERSINKS

## FRAISES À TIGE DROITE GUIDÉES

## SENKER MIT GERADEM FÜHRUNGSZAPFEN-SCHAFT

## AVELLANADORAS CON PILOTO Y ESPIGA RECTA

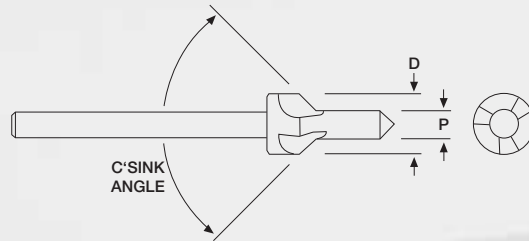

These tools are made to the same specifications as our 150 SERIES countersinks, but with the 3/16" straight shank and from M42 high speed steel, popular in the United Kingdom.

Ces outils sont réalisés selon les spécifications de nos fraises SÉRIE 150, mais avec une tige droite de 3/16 po. et en acier haute vitesse M42, fréquemment utilisé au Royaume Uni.

Diese Werkzeuge werden mit den gleichen Spezifikationen wie unsere 150 SERIES hergestellt. Sie haben jedoch einen geraden Schaft (3/16 Zoll) und sind aus M42-Hochgeschwindigkeitsstahl, der in Großbritannien häufig verwendet wird, gefertigt.

Estas herramientas se fabrican con las mismas especificaciones que las de nuestra SERIE 150, pero con la espi-ga recta de 3/16 pulg. y en acero rápido M42, populares en el Reino Unido.

**SPECIAL SIZES AND ANGLES  
PRICED ON APPLICATION.**

350 SERIES M42 HSSCO 8% STRAIGHT SHANK			
TOOL	"D"	C° SINK ANGLE	"P"
350 - 3/16 - 90° - 3/32	3/16	90°	3/32
350 - 3/16 - 100° - 3/32	3/16	100°	3/32
350 - 3/16 - 120° - 3/32	3/16	120°	3/32
350 - .190 - 100° - 3/32	.190	100°	3/32
350 - 1/4 - 90° - 1/8	1/4	90°	1/8
350 - 1/4 - 100° - 3/32	1/4	100°	3/32
350 - 1/4 - 100° - 1/8	1/4	100°	1/8
350 - 1/4 - 120° - 1/8	1/4	120°	1/8
350 - .252 - 100° - 1/8	.252	100°	1/8
350 - .2830 - 100° - .1935	.283	100°	.1935
350 - 5/16 - 90° - 5/32	5/16	90°	5/32
350 - 5/16 - 100° - 1/8	5/16	100°	1/8
350 - 5/16 - 100° - 5/32	5/16	100°	5/32
350 - 5/16 - 120° - 5/32	5/16	120°	5/32
350 - .340 - 100° - 5/32	.340	100°	5/32
350 - 3/8 - 90° - 3/16	3/8	90°	3/16
350 - 3/8 - 100° - 3/32	3/8	100°	3/32
350 - 3/8 - 100° - 1/8	3/8	100°	1/8
350 - 3/8 - 100° - 5/32	3/8	100°	5/32
350 - 3/8 - 100° - 3/16	3/8	100°	3/16
350 - 3/8 - 120° - 3/32	3/8	120°	3/32
350 - 3/8 - 120° - 1/8	3/8	120°	1/8
350 - 3/8 - 120° - 5/32	3/8	120°	5/32
350 - 3/8 - 120° - 3/16	3/8	120°	3/16
350 - .405 - 100° - 3/16	.405	100°	3/16
350 - 7/16 - 100° - 7/32	7/16	100°	7/32
350 - 7/16 - 100° - 1/4	7/16	100°	1/4
350 - 1/2 - 90° - 1/4	1/2	90°	1/4
350 - 1/2 - 100° - 3/32	1/2	100°	3/32
350 - 1/2 - 100° - 1/8	1/2	100°	1/8
350 - 1/2 - 100° - 5/32	1/2	100°	5/32
350 - 1/2 - 100° - 3/16	1/2	100°	3/16
350 - 1/2 - 100° - 1/4	1/2	100°	1/4
350 - 1/2 - 120° - 1/4	1/2	120°	1/4
350 - .530 - 100° - 1/4	.530	100°	1/4

# 150 PCD SERIES



## INTEGRAL PILOT POLYCRYSTALLINE COUNTERSINK



**HIGHLY ECONOMICAL HOLE PRODUCTION**  
**CONTROLLED FILLET RADIUS**  
**IMPROVED PERFORMANCE**

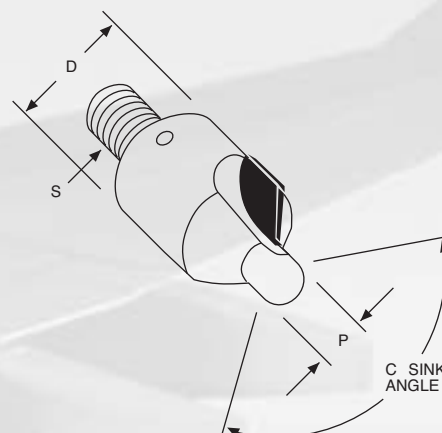

This unique PCD Countersink with the integral pilot and controlled fillet Radius, greatly improves countersinking in advanced composite applications.

TOOL NUMBER	"D" BODY DIA.	"P" PILOT	NUMBER FLUTES	"S" SHANK SIZE	C'SINK ANGLE
150PCD-100/130	3/8	SPECIFY	2	1/4-28	100°/130°
152PCD-100/130	1/2	SPECIFY	2	1/4-28	100°/130°
153PCD-100/130	5/8	SPECIFY	2	1/4-28	100°/130°

# 700 PCD SERIES

## PCD TIPPED STOP COUNTERSINK

Replaceable pilot, threaded shank

**700 SERIES** cutters excel in cutting highly abrasive non-ferrous materials in which carbide will not perform satisfactorily, such as graphite epoxy. A high clearance angle with identical lip height results in chatter free, highly economical hole production.

Replaceable pilot construction allow economical replacement of damaged pilots and substitution of various pilot diameters with the same cutter. (For pilot information see the 755 Series.) Maximum non-cutting diameter is 1/32 larger than pilot hole. See sketch.

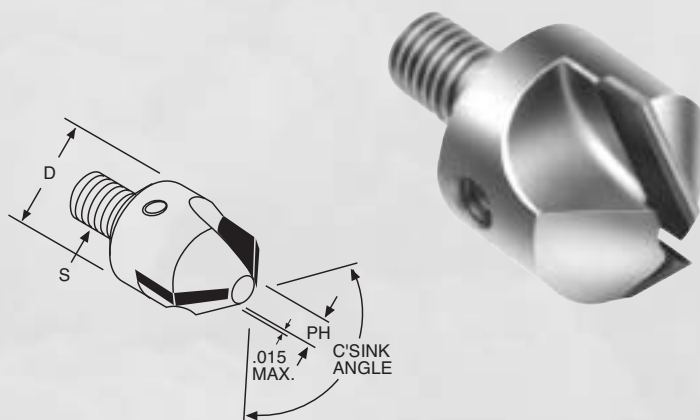

TOOL NUMBER	"D" BODY DIA.	"PH" PILOT HOLE	NUMBER FLUTES	"S" SHANK SIZE	C'SINK ANGLE
700PCD-100/130	3/8	3/32	2	1/4-28	100°/130°
704PCD-100/130	1/2	1/8	2	1/4-28	100°/130°
705PCD-100/130	5/8	1/8	2	1/4-28	100°/130°



# VS SERIES

## VERSI-SINK SYSTEM

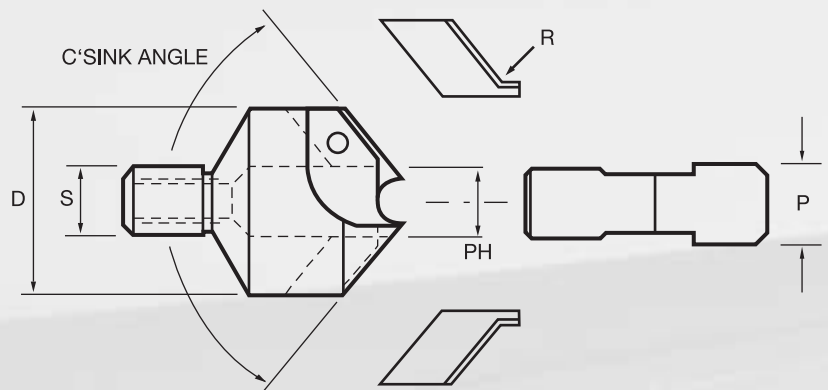

A countersink cutter "SYSTEM" that will dramatically REDUCE you cost per hole, inventories, and production problems.

This system provides the ULTIMATE in versatility for countersinking holes 3/16" diameter and larger, for 100° & 130° fasteners.

This tool was designed to address the problems and high cost encountered countersinking graphite epoxy and other highly abrasive cast, wrought and composite materials in air frame assembly.

Inserts can be supplied with a controlled fillet radius or not, depending upon your requirements.

Your tool crib need only inventory enough tool bodies to provide for your operators, pilots to satisfy the range of holes, and insert to address the proper application.

The bodies, if handled properly, will last indefinitely. As the pilots wear out, you need only replace the pilot. As the inserts become dull they can be returned to the factory for re-sharpening (2 to 3 times), if they haven't been damaged beyond repair. Re-sharpening is at a much lower cost than the purchase of new inserts.

### HOW TO ORDER VERSI-SINK

You can order VERSI-SINK cutters by complete assemblies or by components from any of our authorized distributors

TOOL NO.	COMPLETE ASSEMBLY		
	BODY DIA.	INC. ANGLE	
VS100-1-Material -Pilot-Dia-Radius	5/8	100°	
VS100-2- " " " "	13/16	100°	
VS130-1- " " " "	5/8	130°	
VS130-2- " " " "	13/16	130°	

Examples: VS100 - 1 - D - 3/16 - .03 = 5/8 X 100° - .03 Rad. Diameter Cutter Assembly





## BODIES, PILOTS, INSERTS

### VERSI-SINK SYSTEM

#### HOW THE SYSTEM WORKS

The **"VERSI-SINK"** is a multi-application cutter with three components; the body, pilot and insert set.

#### BODY:

The body is manufactured from heat treated steel. The pilot hole, seat angle and insert pockets are all precision machined to provide concentricity and lip height variation within .001 T.I.R.. The inserts are held mechanically with 4-40 set screws, while registering on the pilot and pocket walls. A stop screw is located in the shank to prevent the pilot from damaging the inserts.

#### PILOT:

The pilots are ground between centers concentric within .0002 T.I.R. The design incorporates a "Locating flat" behind the pilot head for the inserts to register, to maintain the fillet radius tangent to the pilot diameter, regardless of the pilot used.

#### INSERT:

The inserts are precision ground on all sides in MATCHED SETS, to be interchangeable with any body or pilot.

NOTE: the inserts must not be mixed, and must be returned in matched sets for reconditioning.

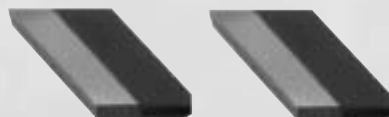
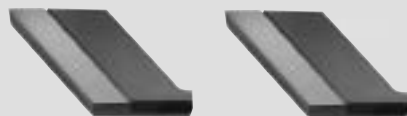

TOOL BODIES						
TOOL NO.	"D" BODY DIA.	"PH" PILOT HOLE	C'SINK ANGLE	MIN PILOT DIA.	MAX PILOT DIA.	"S" SHANK SIZE
TB100-1	5/8	.218	100°	.161	.271	1/4-28
TB100-2	13/16	.343	100°	.250	.423	3/8-24
TB100-3	15/16	.438	100°	.406	.515	3/8-24
TB130-1	5/8	.218	130°	.161	.271	1/4-28
TB130-2	13/16	.343	130°	.250	.423	3/8-24
TB130-3	15/16	.438	130°	.406	.515	3/8-24

PILOTS								
TOOL NO.	for Dash 1 Bodies		for Dash 2 Bodies		for Dash 3 Bodies			
	"P" PILOT DIA.	MAX C'SINK DIA.	"P" PILOT DIA.	MAX C'SINK DIA.	"P" PILOT DIA.	MAX C'SINK DIA.		
655-4-218	.161	.580	655-8-343	.250	.670	655-14-438	.406	.826
655-5-218	.187	.605	655-9-343	.257	.677	655-15-438	.437	.857
655-6-218	.193	.610	655-10-343	.281	.701	655-16-438	.468	.888
655-7-218	.218	.635	655-11-343	.312	.732	655-17-438	.500	.920
655-8-218	.250	.670	655-12-343	.343	.763			
655-9-218	.257	.675	655-13-343	.375	.795			
			655-14-343	.406	.826			

INSERT SETS WITH CONTROLLED RADIUS		
POLYCRYSTALLINE DIAMOND		
TOOL NO.	ANGLE	"R" RADIUS
D100-1-030	100°	.030
D100-2-040	100°	.040
D130-1-030	130°	.030
D130-2-040	130°	.040

INSERT SETS WITH NO RADIUS	
POLYCRYSTALLINE DIAMOND	
TOOL NO.	ANGLE
DP100	100°
DP130	130°



# 150 CT SERIES

## CARBIDE TIPPED STOP COUNTERSINK

Integral pilot, threaded shank

**150CT SERIES** is similar in design to the 150 Series high speed steel cutters. They excel in cutting highly abrasive materials, the "difficult to machine" materials and in cutting material where longer tool life is desired. The tool body is made of high speed steel. Two flute 100° angle is standard. Three flute and special angles subject to quote.

TOOL NUMBER	"D" BODY DIA.	"S" SHANK SIZE	PILOT RANGE
151 CT	7/16	1/4-28	3/32 - 3/16
152 CT	1/2	1/4-28	3/32 - 1/4
153 CT	5/8	1/4-28	5/32 - 5/16
155 CT	3/4	3/8-24	1/4 - 3/8
156 CT	7/8	3/8-24	1/4 - 7/16
157 CT	1	3/8-24	5/16 - 1/2

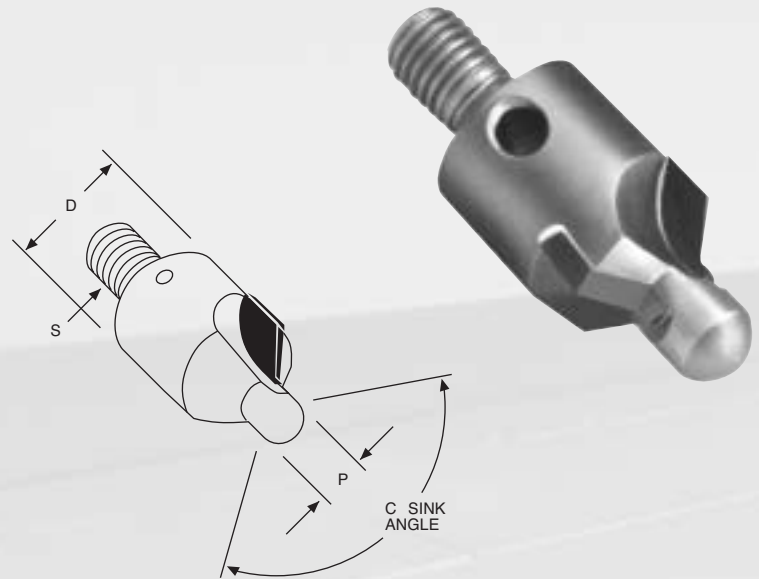

# 150 SC SERIES

## SOLID CARBIDE STOP COUNTERSINK

Integral pilot, threaded shank

**150SC SERIES** is similar in design to the 150CT Series except tool is made with solid carbide head but brazed to steel shank giving pilot equal wear resistance to cutting edge. Two flute 100° angle is standard. Three flute and special angles subject to quote.

TOOL NUMBER	"D" BODY DIA.	"S" SHANK SIZE	PILOT RANGE
151 SC	7/16	1/4-28	3/32 - 3/16
152 SC	1/2	1/4-28	3/32 - 1/4
153 SC	5/8	1/4-28	5/32 - 5/16
155 SC	3/4	3/8-24	1/4 - 3/8
156 SC	7/8	3/8-24	1/4 - 7/16
157 SC	1	3/8-24	5/16 - 1/2

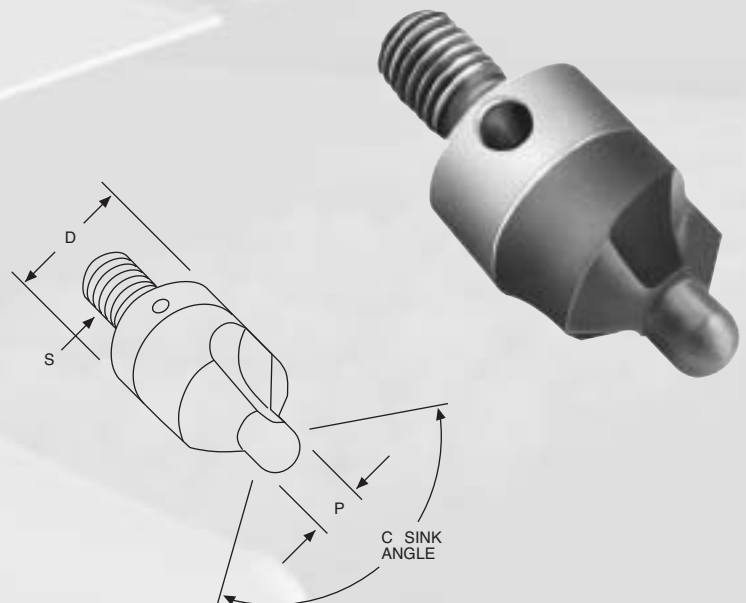

### HOW TO ORDER THREADED SHANK INTEGRAL PILOT COUNTERSINK CUTTERS

**When ordering please specify:** Tool number, Number of flutes, Material Include angle and Pilot diameter

**Example:** 152 - 2CT - 100° - 3/16 = 1/2 x 100° x 3/16, Carbide tipped, 1/4-28, 2 flute.

Standard pilot diameters 3/32, 1/8, 5/32, 3/16, 1/4, 5/16, 3/8, 7/16, 1/2, #40, #30, #21, #11, #10

# 250 SERIES



## HIGH SPEED STEEL UNDERCUT BODY COUNTERSINKS

**250 SERIES** is a two flute high speed steel countersink with an undercut body diameter providing faster chip ejection. They are designed for close tolerance countersinking and to eliminate sheet damage. Two flute 100° angle is standard.

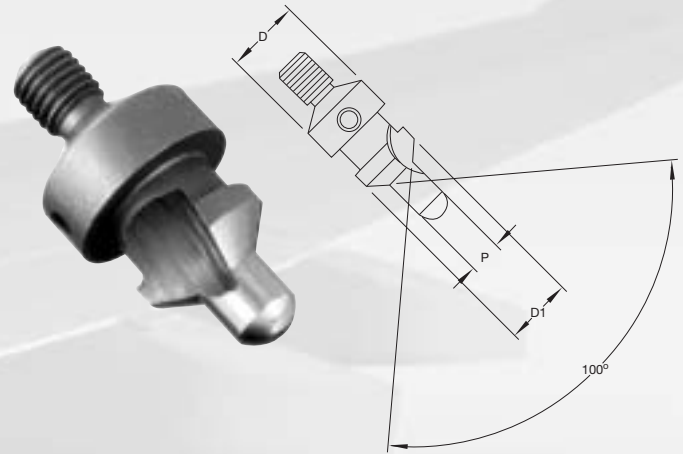

TOOL NUMBER	"D" BODY DIA.	"D1" DIA.	"P" PILOT DIA
250-2-100-210-.0960	3/8	.210	.0960
250-2-100-256-.0980	3/8	.256	.0980
250-2-100-256-.1222	3/8	.256	.1222
250-2-100-210-.1265	3/8	.256	.1265
250-2-100-317-.1570	3/8	.317	.1570
250-2-100-386-.1915	3/8	.386	.1915

# 150 SERIES

## HIGH SPEED AND COBALT STEEL STOP COUNTERSINKS

Integral pilot, threaded shank

**150 SERIES** countersink cutters may be used in all popular adjustable-stop or micro-stop type countersinking units utilizing a threaded shank drive.

Made from the finest high speed steel and also available in cobalt steel. Form relieved to insure concentricity of countersink angle, pilot and seat angle. Standard in three and two flutes. List prices for 100° angle only, other angles and sizes are available subject to quotation.

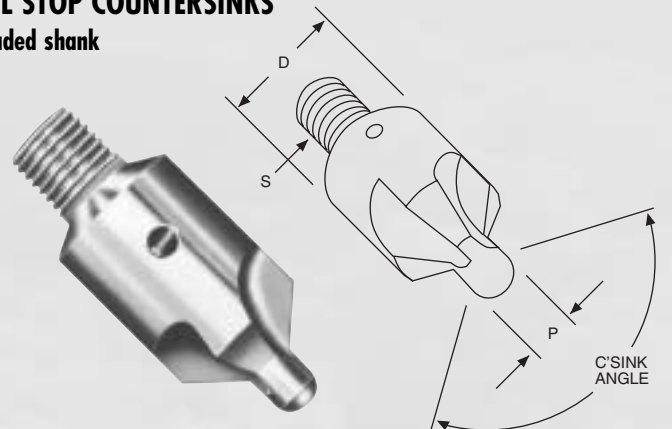

TOOL NUMBER	"D" BODY DIA.	"S" SHANK SIZE	PILOT RANGE
150	3/8	1/8-28	3/32 - 3/16
151	7/16	1/4-28	3/32 - 3/16
152	1/2	1/4-28	3/32 - 1/4
153	5/8	1/4-28	5/32 - 5/16
154	5/8	3/8-24	5/32 - 5/16
155A	3/4	3/8-24	1/4 - 3/8
155B	3/4	7/16-20	1/4 - 3/8
156A	7/8	3/8-24	1/4 - 7/16
156B	7/8	7/16-20	1/4 - 7/16

### HOW TO ORDER THREADED SHANK INTEGRAL PILOT COUNTERSINK CUTTERS

When ordering please specify: Tool number, Number of flutes, Material Include angle and Pilot diameter

**Example:** 150 - 3 - 100 - #40 = 3/8 X 100° X .097 HSS 1/4 - 28 shank, three flute  
 153 - 2C - 90 - 1/4 = 5/8 X 90° X .249 Cobalt 1/4 - 2 8 shank, two flute



# 700 SERIES

## CARBIDE TIPPED STOP COUNTERSINKS

Replaceable pilot, threaded shank

**700 SERIES** carbide countersink cutters excel in cutting highly abrasive materials, and are recommended for countersinking the "difficult to machine" and "exotic" materials in which high speed steel will not perform satisfactorily. Also recommended for any applications where longer tool life is desired.

Replaceable pilot construction allows economical replacement of damaged pilots and substitution of various pilot diameters with the same cutter. (For pilot information see the 755 Series.) Maximum non-cutting diameter is 1/32 larger than the pilot hole. Recommend using cutters with pilot holes 1/32 minimum smaller than the desired pilot diameter, see sketch.

Made with heavy carbide tipped cutting edges brazed to a tough steel body. Precision ground and form relieved to insure concentricity. May be used on all popular adjustable-stop or micro-stop type countersinking units utilizing a threaded shank drive.

Standard in 100°. Other angles subject to quote.

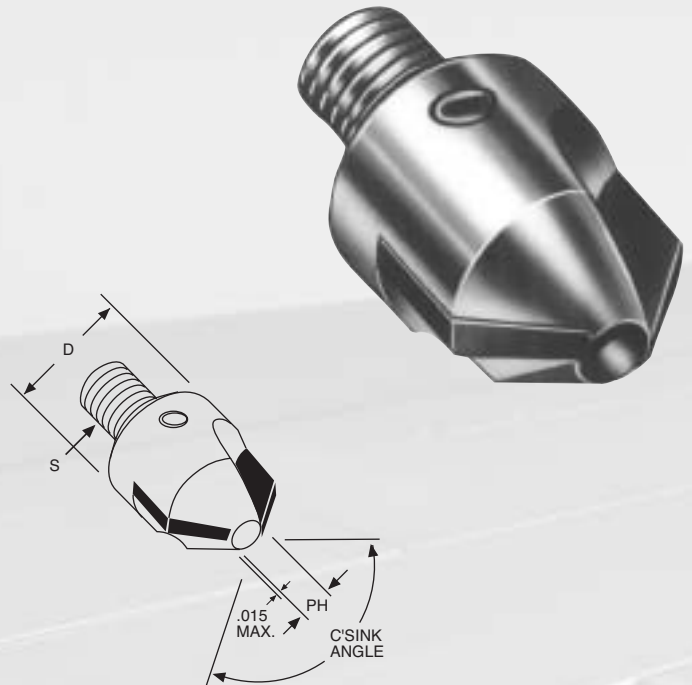

TOOL NUMBER	"D" BODY DIA.	"PH" PILOT HOLE	NUMBER FLUTES	"S" SHANK SIZE
700	3/8	5/64	2	1/4-28
701	7/16	5/64	2	1/4-28
702	1/2	5/64	2	1/4-28
703	1/2	3/32	2	1/4-28
704	1/2	1/8	2	1/4-28
705	5/8	1/8	2	1/4-28
706	5/8	3/16	2	1/4-28
707A	3/4	3/16	3	3/8-24
707B	3/4	3/16	3	7/16-20
708A	7/8	3/16	3	3/8-24
708B	7/8	3/16	3	7/16-20
709A	1	3/16	3	3/8-24
709B	1	3/16	3	7/16-20
710A	1-1/8	1/4	3	3/8-24
710B	1-1/8	1/4	3	7/16-20
711A	1-1/4	1/4	3	3/8-24
711B	1-1/4	1/4	3	7/16-20

**When ordering please specify:** Tool number, and include countersink angle.  
**Example:** 701 - 100°. For pilot information see 755 Series. Current prices for 100° included countersink angles only.  
Other angles and sizes available, subject to quotation.



## CARBIDE TIPPED STOP COUNTERBORES

Replaceable pilot, threaded shank



**730 SERIES** carbide stop counterbore cutters may be used in all popular adjustable-stop or micro-stop type countersinking units utilizing a threaded shank drive.

They combine the advantages of Craig's 850 Series carbide aircraft counterbores with the positive stop feature of the adjustable-stop countersinking units.

730 Series cutters excel in cutting highly abrasive materials, and are recommended for spotfacing the "difficult to machine" and "exotic" materials in which high speed steel will not perform satisfactorily. Also recommended for any application where longer tool life is desired.

Special "D" cutter diameter may be readily ground from standard sizes listed. Special cutters given prompt attention. All cutters supplied with 1/64 corner radius. Maximum noncutting diameter is 1/32 larger than pilot hole, see sketch. Use pilots with "H" head diameter 1/32 minimum larger than "S" shank diameter. For pilot information see 755 Series.

Special "D" diameter's and/or radii subject to quote.

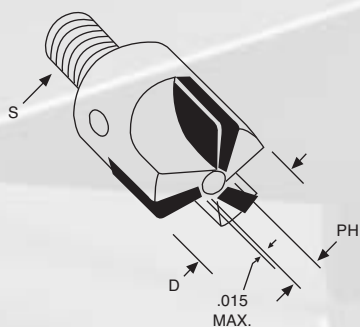

TOOL NUMBER	"D" CUTTER DIA.	"P" PILOT HOLE	"S" SHANK SIZE
730-1	3/8	3/32	1/4-28
730-2	7/16	1/8	1/4-28
730-3	1/2	1/8	1/4-28
730-4	9/16	1/8	1/4-28
730-5	5/8	1/8	1/4-28
730-6A	11/16	3/16	3/8-24
730-6B	11/16	3/16	7/16-20
730-7A	3/4	3/16	3/8-24
730-7B	3/4	3/16	7/16-20
730-8A	13/16	3/16	3/8-24
730-8B	13/16	3/16	7/16-20
730-9A	7/8	3/16	3/8-24
730-9B	7/8	3/16	7/16-20
730-10A	15/16	3/16	3/8-24
730-10B	15/16	3/16	7/16-20
730-11A	1	3/16	3/8-24
730-11B	1	3/16	7/16-20
730-12A	1-1/8	3/16	3/8-24
730-12B	1-1/8	3/16	7/16-20
730-13A	1-1/4	3/16	3/8-24
730-13B	1-1/4	3/16	7/16-20





# 755 SERIES

## PILOTS FOR CARBIDE TIPPED STOP COUNTERBORES & COUNTERSINKS

**755 SERIES** pilots are designed for use with 700 Series carbide countersinks and 730 Series carbide counterbores. Made from finest quality tool steel, heat treated throughout and precision ground to exacting size and concentricity tolerances.

Standard without a shank flat. Tools with flat subject to quote.



TOOL NUMBER	PILOT HEAD NOMINAL DIA.	STANDARD SHANK DIAMETER			
		5/64	3/32	1/8	3/16
755-1	1/8(.125)	•	•		
755-2	#30(.128)	•	•		
755-3	5/32(.156)	•	•	•	
755-4	#20(.161)	•	•	•	
755-5	3/16(.187)	•	•	•	
755-6	#10(.193)	•	•	•	
755-7	7/32(.218)	•	•	•	•
755-8	1/4(.250)	•	•	•	•
755-9	"F"(.257)		•	•	•
755-10	9/32(.281)			•	•
755-11	5/16(.312)			•	•
755-12	11/32(.343)				•
755-13	3/8(.375)				•
755-14	13/32(.406)				•
755-15	7/16(.437)				•
755-16	15/32(.468)				•
755-17	1/2(.500)				•
755-18	17/32(.531)				•
755-19	9/16(.562)				•
755-20	19/32(.531)				•
755-21	5/8(.625)				•

When ordering please specify: Tool number and standard shank diameter. **Example:** 755-7-1/8,

• Denotes standard sizes

# OFFSET ANGLE DRILLS



All offset angle head drilling attachments feature hardened and ground bearing supported shafts. **BE700 SERIES** units have bearing supported spindle gears.

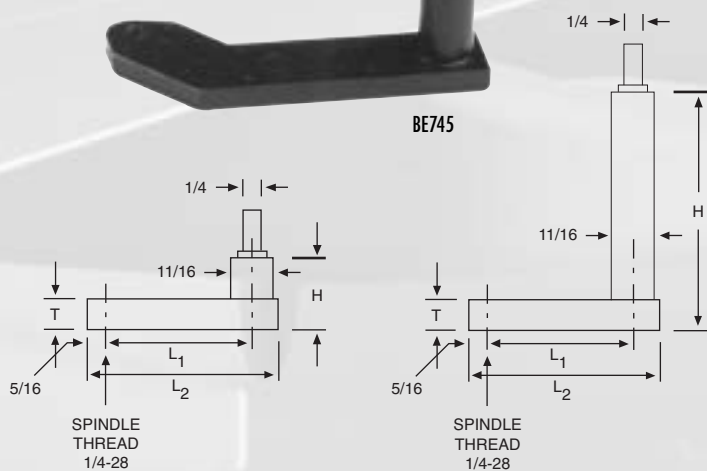
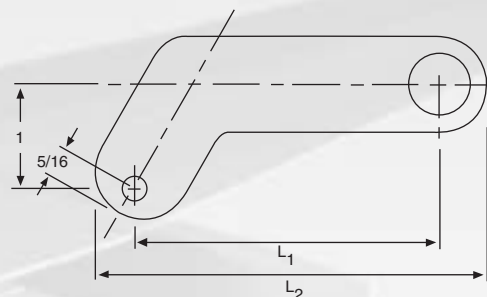

MODEL	T	L1	L2	H	STYLE
BE720	3/8	2-7/16	3-3/16	1-1/8	Straight
BE725	3/8	2-7/16	3-3/16	4-9/16	Straight
BE730	3/8	3-3/4	4-1/2	1-1/8	Straight
BE735	3/8	3-3/4	4-1/2	4-9/16	Straight
BE745	3/8	3-1/8	4	4-9/16	30 Deg. RH
BE755	3/8	3-1/8	4	4-9/16	30 Deg. LH

# DRILL / COLLET CHUCKS

Collet and drill chucks are used to adapt straight shank cutters to threaded spindle tools.

PART NUMBER	SIZE/CAPACITY	SHANK	OAL
BE1005-10	#10 (.1935)	1/4-28	7/8
BE1005-20	#20 (.1610)	1/4-28	7/8
BE1005-30	#30 (.1285)	1/4-28	7/8
BE1005-40	#40 (.0980)	1/4-28	7/8
BE1005-1/4	1/4 (.2500)	1/4-28	7/8
BE1005-F	"F" (.2570)	1/4-28	7/8
BE1010	5/64 - "F"	1/4-28	1-1/4





# 848 SERIES

## HIGH SPEED STEEL AIRCRAFT COUNTERBORES

Replaceable pilot, straight shank

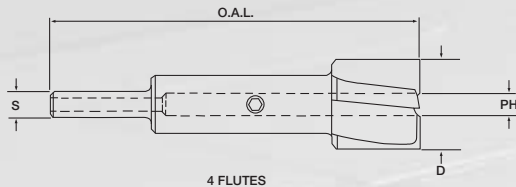

**848 SERIES** counterbores with short, sturdy design are ideal for use in portable drill motors and drill presses. Made from the finest high speed steel.

**All counterbores are furnished with sharp corners.**

Special "D" cutter diameters, and special radii may be readily ground from standard sizes listed. Special sizes and radii are given prompt attention. For pilot information see 855 Series.

TOOL NUMBER	"D" CUTTER DIA.	"PH" PILOT HOLE DIA.	"S" SHANK DIA.	O.A.L. REF.
848-1-NCR	1/4	3/32	1/4	2-3/8
848-2-NCR	9/32	3/32	1/4	2-3/8
848-3-NCR	5/16	3/32	1/4	2-3/8
848-4-NCR	11/32	3/32	1/4	2-3/8
848-5-NCR	3/8	3/32	1/4	2-3/8
848-6-NCR	13/32	1/8	1/4	2-13/16
848-7-NCR	7/16	1/8	1/4	2-13/16
848-8-NCR	15/32	1/8	1/4	2-13/16
848-9-NCR	1/2	1/8	1/4	2-13/16
848-10-NCR	17/32	1/8	1/4	2-13/16
848-11-NCR	9/16	1/8	1/4	2-13/16
848-12-NCR	19/32	1/8	1/4	2-13/16
848-13-NCR	5/8	1/8	1/4	2-13/16
848-14-NCR	21/32	3/16	1/4	3-1/8
848-15-NCR	11/16	3/16	1/4	3-1/8
848-16-NCR	23/32	3/16	1/4	3-1/8
848-17-NCR	3/4	3/16	1/4	3-1/8
848-18-NCR	25/32	3/16	1/4	3-1/8
848-19-NCR	13/16	3/16	1/4	3-1/8
848-20-NCR	27/32	3/16	1/4	3-1/8
848-21-NCR	7/8	3/16	1/4	3-1/8
848-22-NCR	29/32	3/16	1/4	3-1/8
848-23-NCR	15/16	3/16	1/4	3-1/8
848-24-NCR	31/32	3/16	1/4	3-1/8
848-25-NCR	1	3/16	1/4	3-1/8
848-26-NCR	1-1/16	3/16	1/2	2-3/4
848-27-NCR	1-1/8	3/16	1/2	2-3/4
848-28-NCR	1-3/16	3/16	1/2	2-3/4
848-29-NCR	1-1/4	3/16	1/2	2-3/4
848-30-NCR	1-5/16	3/16	1/2	2-3/4
848-31-NCR	1-3/8	3/16	1/2	2-3/4
848-31B-NCR	1-7/16	3/16	1/2	2-3/4
848-32-NCR	1-1/2	3/16	1/2	2-3/4

# HC SERIES

## HIGH SPEED STEEL HOLLOW CUTTERS

Threaded shank



TOOL NUMBER	"D" CUTTER DIA.	"H" HOLE DIA.	RIVET SIZE
HC-1	.365	.125	1/8 Hi-shear
HC-2	.365	.156	5/32 Hi-shear
HC-3	.438	.187	3/16 Hi-shear
HC-4	.500	.250	1/4 Hi-shear
HC-5	.562	.312	5/16 Hi-shear
HC-6	.625	.375	3/8 Hi-shear
HC-11	.323	.187	3/16 Huck Lock Bolt
HC-12	.413	.250	1/4 Huck Lock Bolt
HC-14	.528	.312	5/16 Huck Lock Bolt



## CARBIDE TIPPED AIRCRAFT COUNTERBORES

Replaceable pilot, straight shank

TOOL NUMBER	"D" CUTTER DIA.	"PH" PILOT HOLE DIA.	"S" SHANK DIA.	O.A.L. OVERALL LENGTH
850-1	1/4	3/32	1/4	2-3/8
850-2	9/32	3/32	1/4	2-3/8
850-3	5/16	3/32	1/4	2-3/8
850-4	11/32	3/32	1/4	2-3/8
850-5	3/8	3/32	1/4	2-3/8
850-6	13/32	1/8	1/4	2-3/4
850-7	7/16	1/8	1/4	2-3/4
850-8	15/32	1/8	1/4	2-3/4
850-9	1/2	1/8	1/4	2-3/4
850-10	17/32	1/8	1/4	2-3/4
850-11	9/16	1/8	1/4	2-3/4
850-12	19/32	1/8	1/4	2-3/4
850-13	5/8	1/8	1/4	2-3/4
850-14	21/32	3/16	1/4	2-3/4
850-15	11/16	3/16	1/4	2-3/4
850-16	23/32	3/16	1/4	2-3/4
850-17	3/4	3/16	1/4	2-3/4
850-18	25/32	3/16	1/4	2-3/4
850-19	13/16	3/16	1/4	2-3/4
850-20	27/32	3/16	1/4	2-3/4
850-21	7/8	3/16	1/4	2-3/4
850-22	29/32	3/16	1/4	2-3/4
850-23	15/16	3/16	1/4	2-3/4
850-24	31/32	3/16	1/4	2-3/4
850-25	1	3/16	1/4	2-3/4
850-26	1-1/16	3/16	3/8	2-3/4
850-27	1-1/8	3/16	3/8	2-3/4
850-28	1-3/16	1/4	3/8	2-3/4
850-29	1-1/4	1/4	3/8	2-3/4
850-30	1-5/16	1/4	3/8	2-3/4
850-31	1-3/8	1/4	3/8	2-3/4
850-31B	1-7/16	1/4	3/8	2-3/4
850-32	1-1/2	1/4	3/8	2-3/4
850-33	1-9/16	5/16	1/2	3-1/16
850-34	1-5/8	5/16	1/2	3-1/16
850-35	1-11/16	5/16	1/2	3-1/16
850-36	1-3/4	5/16	1/2	3-1/16
850-37	1-13/16	5/16	1/2	3-1/16
850-38	1-7/8	5/16	1/2	3-1/16
850-39	1-15/16	5/16	1/2	3-1/16
850-40	2	5/16	1/2	3-1/16

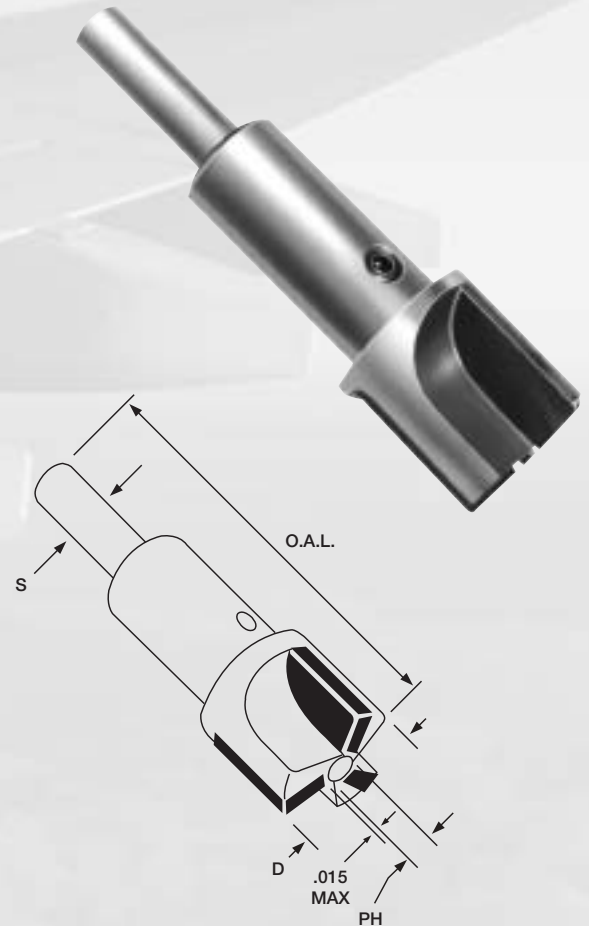

**850 SERIES** carbide counterbores are similar in design to the 848 Series high speed steel cutters. They excel in cutting highly abrasive materials, and are recommended for counterboring and spot-facing the "difficult-to-machine" and "exotic" materials in which high speed steel will not perform satisfactorily. Also recommended for any application where longer tool life is desired.

Special "D" cutter diameters may be readily ground from standard sizes listed. Special cutters given prompt attention.

All cutters furnished with 1/64 corner radius. Maximum non-cutting diameter is 1/32 larger than the pilot hole. Recommend using pilots with "H" head diameter 1/32 minimum larger than "S" shank diameter. For pilot information see 855 Series.



# 855 SERIES

## PILOTS FOR AIRCRAFT COUNTERBORES

**855 SERIES** pilots are designed for use with 848 Series and 850 Series aircraft counterbores. Will fit almost all standard aircraft counterbores. Made from finest quality tool steel, heat treated throughout and precision ground to exacting size and concentricity tolerances.

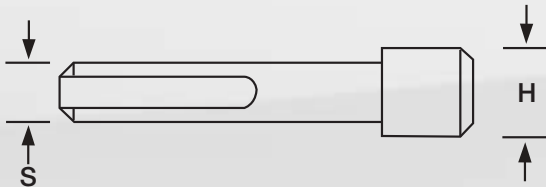

When ordering please specify: Tool number and standard shank diameter. **Example:** 855-7-1/8

• Denotes standard sizes.

TOOL NUMBER	PILOT HEAD NOMINAL DIA.	STANDARD SHANK DIAMETERS					
		3/32	1/8	5/32	3/16	1/4	5/16
855-1	3/32(.093)	•					
855-2	1/8(.125)	•	•				
855-3	5/32(.156)	•	•	•			
855-4	#20(.161)	•	•	•			
855-5	3/16(.187)	•	•	•	•		
855-6	#10(.193)	•	•	•	•		
855-7	7/32(.218)	•	•	•	•		
855-8	1/4(.250)	•	•	•	•	•	
855-9	"F"(.257)	•	•	•	•	•	
855-10	9/32(.281)		•	•	•	•	
855-11	5/16(.312)		•	•	•	•	•
855-12	11/32(.343)			•	•	•	•
855-13	3/8(.375)			•	•	•	•
855-14	13/32(.406)			•	•	•	•
855-15	7/16(.437)			•	•	•	•
855-16	15/32(.468)			•	•	•	•
855-17	1/2(.500)			•	•	•	•
855-18	17/32(.531)				•	•	•
855-19	9/16(.562)				•	•	•
855-20	19/32(.593)				•	•	•
855-21	5/8(.625)				•	•	•
855-22	21/32(.656)					•	•
855-23	11/16(.687)					•	•
855-24	23/32(.718)					•	•
855-25	3/4(.750)					•	•
855-26	25/32(.781)						•
855-27	13/16(.812)						•
855-28	7/8(.875)						•
855-29	15/16(.937)						•
855-30	1(1.00)						•





## COARSE AND FINE TOOTH HOLE SAWS AND ARBORS

**HSC / HSF SERIES** hole saw cutters are designed for hole making in aluminum and steel. Made from High Speed Steel, they work well in both thin and thick sections.



**STOCK SIZES:**

- 3/8" – 2" DIA. IN INCREMENTS OF 1/32"
- 2" – 3" DIA. IN INCREMENTS OF 1/16"
- 3" – 4" DIA. IN INCREMENTS OF 1/8"

**STOCK SIZES:**

- 3/8" THRU 1 15/32" HAVE 5/16-24 HOLE
- 1 1/2" THRU 4" HAVE 1/2-20 HOLE

**HSA SERIES** hole saw arbor carried in stock in the sizes shown. Special pilot diameters priced on request.



TOOL NUMBER	HOLE SAW NOMINAL DIA.	TOOL NUMBER	HOLE SAW NOMINAL DIA.
HSC/HSF-1	3/8	HSC/HSF-23	1-3/16
HSC/HSF-1A	13/32	HSC/HSF-24	1-1/4
HSC/HSF-2	7/16	HSC/HSF-25	1-5/16
HSC/HSF-2A	15/32	HSC/HSF-26	1-3/8
HSC/HSF-3	1/2	HSC/HSF-27	1-7/16
HSC/HSF-3A	17/32	HSC/HSF-28	1-1/2
HSC/HSF-4	9/16	HSC/HSF-29	1-9/16
HSC/HSF-4A	19/32	HSC/HSF-30	1-5/8
HSC/HSF-5	5/8	HSC/HSF-31	1-11/16
HSC/HSF-5A	21/32	HSC/HSF-32	1-3/4
HSC/HSF-6	11/16	HSC/HSF-33	1-13/16
HSC/HSF-6A	23/32	HSC/HSF-34	1-7/8
HSC/HSF-7	3/4	HSC/HSF-35	1-15/16
HSC/HSF-7A	25/32	HSC/HSF-36	2.0
HSC/HSF-8	13/16	HSC/HSF-37	2-1/8
HSC/HSF-8A	27/32	HSC/HSF-38	2-1/4
HSC/HSF-9	7/8	HSC/HSF-39	2-3/8
HSC/HSF-9A	29/32	HSC/HSF-40	2-1/2
HSC/HSF-10	15/16	HSC/HSF-41	2-5/8
HSC/HSF-10A	31/32	HSC/HSF-42	2-3/4
HSC/HSF-11	1.0	HSC/HSF-43	2-7/8
HSC/HSF-21	1-1/16	HSC/HSF-44	3.0
HSC/HSF-22	1-1/8		

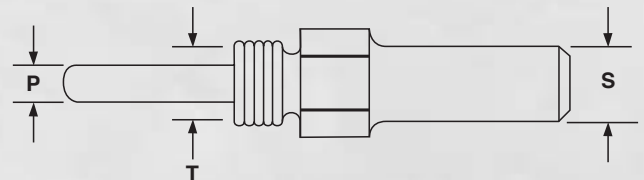

P	T	S	DASH NO.
3/16	5/16 - 24	1/4	HSA - 1
1/4	5/16 - 24	1/4	HSA - 2
1/4	1/2 - 20	1/2	HSA - 3
3/8	1/2 - 20	1/2	HSA - 4
1/4	1/2 - 20	3/8	HSA - 5
3/8	1/2 - 20	3/8	HSA - 6
1/4	1/2 - 20	1/4	HSA - 7



# 180 SERIES

## HIGH SPEED STEEL REVERSE COUNTERSINKS

**180 SERIES** reverse countersinks are designed for use in restricted areas where conventional countersink cutters cannot be utilized. Made from the finest high speed tool steel, precision ground and form relieved.

Standard with 100° countersink angle. Special "D" cutter diameters readily ground from standard. Special sizes given prompt attention.

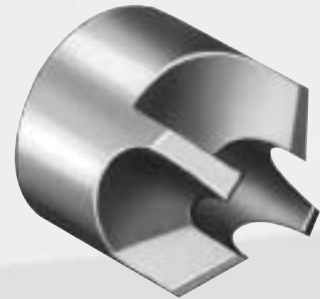

TOOL NUMBER	"D" CUTTER DIA.	"PH" PILOT HOLE	NUMBER FLUTES	PILOT REF.*		OAL
				PLAIN PILOT	STEP PILOT	
180-1J	1/4	3/32	3	185-1	186-1	1/2
180-1K	1/4	1/8	3	185-2	186-2	1/2
180-2J	5/16	3/32	3	185-1	186-1	1/2
180-2K	5/16	1/8	3	185-2	186-2	1/2
180-2L	5/16	5/32	3	185-3	186-3	1/2
180-3J	3/8	1/8	3	185-2	186-2	1/2
180-3K	3/8	5/32	3	185-3	186-3	1/2
180-3L	3/8	3/16	3	185-4	186-4	1/2
180-4J	7/16	1/8	3	185-2	186-2	1/2
180-4K	7/16	5/32	3	185-3	186-3	1/2
180-4L	7/16	3/16	3	185-4	186-4	1/2
180-5J	1/2	5/32	3	185-3	186-3	1/2
180-5K	1/2	3/16	3	185-4	186-4	1/2
180-5L	1/2	1/4	3	185-5	186-5	1/2
180-6J	9/16	5/32	4	185-3	186-6	5/8
180-6K	9/16	3/16	4	185-4	186-7	5/8
180-6L	9/16	1/4	4	185-5	186-8	5/8
180-7J	5/8	3/16	4	185-4	186-7	5/8
180-7K	5/8	1/4	4	185-5	186-8	5/8
180-7L	5/8	5/16	4	185-6	186-9	5/8
180-8J	11/16	3/16	4	185-4	186-7	5/8
180-8K	11/16	1/4	4	185-5	186-8	5/8
180-8L	11/16	5/16	4	185-6	186-9	5/8
180-9J	3/4	1/4	4	185-5	186-12	7/8
180-9K	3/4	5/16	4	185-6	186-13	7/8
180-9L	3/4	3/8	4	185-7	186-14	7/8
180-10J	7/8	1/4	4	185-5	186-12	7/8
180-10K	7/8	5/16	4	185-6	186-13	7/8
180-10L	7/8	3/8	4	185-7	186-14	7/8
180-11J	1	5/16	4	185-6	186-13	7/8
180-11K	1	3/8	4	185-7	186-14	7/8
180-11L	1	1/2	4	185-8	186-17	7/8
180-12J	1-1/4	3/8	4	185-7	186-18	1 1/8
180-12K	1-1/4	1/2	4	185-8	186-19	1 1/8

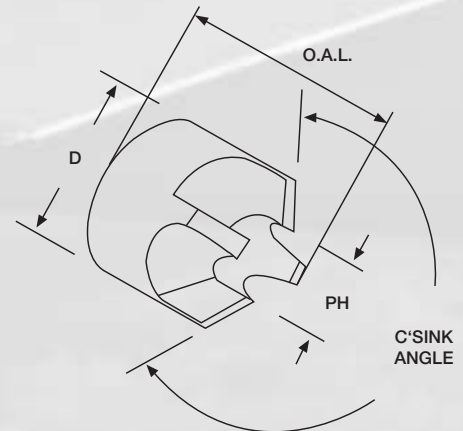

When ordering please specify: Tool number and included countersink angle.  
**Example:** 180 - 5K - 100°. List prices for 100° countersink angle only. Other angles and sizes available, subject to quotation.

\*For pilot information see 185 Series and 186 Series.



## CARBIDE REVERSE COUNTERSINKS



**181 SERIES** carbide reverse countersinks are similar in design to the 180 Series high speed cutters. They excel in cutting highly abrasive materials, the "difficult to machine" materials, and in cutting any material where longer tool life is desired. 186 Series step pilots are recommended for use with carbide tipped cutters as tipped cutters have a maximum non-cutting diameter 1/32 larger than pilot hole, see sketch.

Standard in three flutes with 100° countersink angle. Special "D" cutter diameters readily ground from standard. Special sizes given prompt attention.

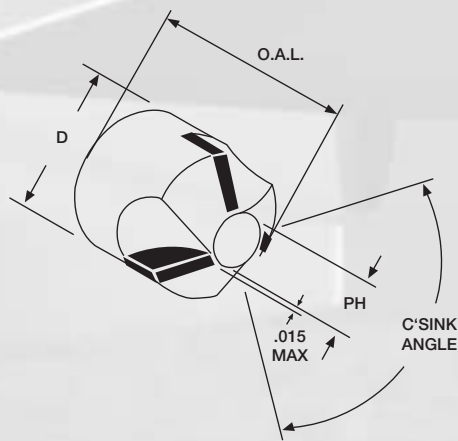

When ordering please specify: Tool number and included countersink angle.  
**Example:** 180 - 5J - 100°. List prices for 100° countersink angle only. Other angles and sizes available, subject to quotation.

\*For pilot information see 185 Series and 186 Series.

TOOL NUMBER	"D" CUTTER DIA.	"PH" PILOT HOLE	CONSTRUCTION	PILOT REF.*		OAL
				PLAIN PILOT	STEP PILOT	
181-1J	1/4	3/32	Solid Carbide	185-1	186-1	1/2
181-1K	1/4	1/8	Solid Carbide	185-2	186-2	1/2
181-2J	5/16	3/32	Solid Carbide	185-1	186-1	1/2
181-2K	5/16	1/8	Solid Carbide	185-2	186-2	1/2
181-2L	5/16	5/32	Solid Carbide	185-3	186-3	1/2
181-3J	3/8	1/8	Solid Carbide	185-2	186-2	1/2
181-3K	3/8	5/32	Solid Carbide	185-3	186-3	1/2
181-3L	3/8	3/16	Solid Carbide	185-4	186-4	1/2
181-4J	7/16	1/8	Solid Carbide	185-2	186-2	1/2
181-4K	7/16	5/32	Solid Carbide	185-3	186-3	1/2
181-4L	7/16	3/16	Solid Carbide	185-4	186-4	1/2
181-5J	1/2	5/32	Solid Carbide	185-3	186-3	1/2
181-5K	1/2	3/16	Solid Carbide	185-4	186-4	1/2
181-5L	1/2	1/4	Solid Carbide	185-5	186-5	1/2
181-6J	9/16	5/32	Solid Carbide	185-3	186-6	5/8
181-6K	9/16	3/16	Solid Carbide	185-4	186-7	5/8
181-6L	9/16	1/4	Solid Carbide	185-5	186-8	5/8
181-7J	5/8	3/16	Solid Carbide	185-4	186-7	5/8
181-7K	5/8	1/4	Solid Carbide	185-5	186-8	5/8
181-7L	5/8	5/16	Solid Carbide	185-6	186-9	5/8
181-8J	11/16	3/16	Solid Carbide	185-4	186-7	5/8
181-8K	11/16	1/4	Solid Carbide	185-5	186-8	5/8
181-8L	11/16	5/16	Solid Carbide	185-6	186-9	5/8
181-9J	3/4	1/4	Solid Carbide	185-5	186-12	7/8
181-9K	3/4	5/16	Solid Carbide	185-6	186-13	7/8
181-9L	3/4	3/8	Solid Carbide	185-7	186-14	7/8
181-10J	7/8	1/4	Solid Carbide	185-5	186-12	7/8
181-10K	7/8	5/16	Solid Carbide	185-6	186-13	7/8
181-10L	7/8	3/8	Solid Carbide	185-7	186-14	7/8
181-11J	1	5/16	Solid Carbide	185-6	186-13	7/8
181-11K	1	3/8	Solid Carbide	185-7	186-14	7/8
181-11L	1	1/2	Solid Carbide	185-8	186-17	7/8
181-12J	1-1/4	3/8	Carbide Tipped		186-18	1 1/8
181-12K	1-1/4	1/2	Carbide Tipped		186-19	1 1/8



# 190 SERIES

## HIGH SPEED STEEL REVERSE SPOTFACERS

TOOL NUMBER	"D" CUTTER DIA.	"PH" PILOT HOLE	PILOT REF.*		OAL
			PLAIN PILOT	STEP PILOT	
190-1J	1/4	3/32	185-1	186-1	1/2
190-1K	1/4	1/8	185-2	186-2	1/2
190-2J	5/16	3/32	185-1	186-1	1/2
190-2K	5/16	1/8	185-2	186-2	1/2
190-2L	5/16	5/32	185-3	186-3	1/2
190-3J	3/8	1/8	185-2	186-2	1/2
190-3K	3/8	5/32	185-3	186-3	1/2
190-3L	3/8	3/16	185-4	186-4	1/2
190-4J	7/16	1/8	185-2	186-2	1/2
190-4K	7/16	5/32	185-3	186-3	1/2
190-4L	7/16	3/16	185-4	186-4	1/2
190-5J	1/2	5/32	185-3	186-3	1/2
190-5K	1/2	3/16	185-4	186-4	1/2
190-5L	1/2	1/4	185-5	186-5	1/2
190-6J	9/16	5/32	185-3	186-6	5/8
190-6K	9/16	3/16	185-4	186-7	5/8
190-6L	9/16	1/4	185-5	186-8	5/8
190-7J	5/8	3/16	185-4	186-7	5/8
190-7K	5/8	1/4	185-5	186-8	5/8
190-7L	5/8	5/16	185-6	186-9	5/8
190-8J	11/16	3/16	185-4	186-7	5/8
190-8K	11/16	1/4	185-5	186-8	5/8
190-8L	11/16	5/16	185-6	186-9	5/8
190-9J	3/4	1/4	185-5	186-8	5/8
190-9K	3/4	5/16	185-6	186-9	5/8
190-9L	3/4	3/8	185-7	186-10	5/8
190-10J	7/8	1/4	185-5	186-8	5/8
190-10K	7/8	5/16	185-6	186-9	5/8
190-10L	7/8	3/8	185-7	186-10	5/8
190-11J	1	5/16	185-6	186-9	5/8
190-11K	1	3/8	185-7	186-10	5/8
190-11L	1	1/2	185-8	186-11	5/8
190-11M	1-1/8	3/8	185-7	186-14	7/8
190-11N	1-1/8	1/2	185-8	186-17	7/8
190-12J	1-1/4	3/8	185-7	186-14	7/8
190-12K	1-1/4	1/2	185-8	186-17	7/8
190-13J †	1-3/8	5/8	185-9	186-20,21	7/8
190-14J †	1-1/2	5/8	185-9	186-20,21	7/8
190-15J †	1-5/8	3/4	185-10	186-22,23,24	1
190-16J †	1-3/4	3/4	185-10	186-22,23,24	1
190-17J †	1-7/8	3/4	185-10	186-22,23,24	1
190-18J †	2	3/4	185-10	186-22,23,24	1

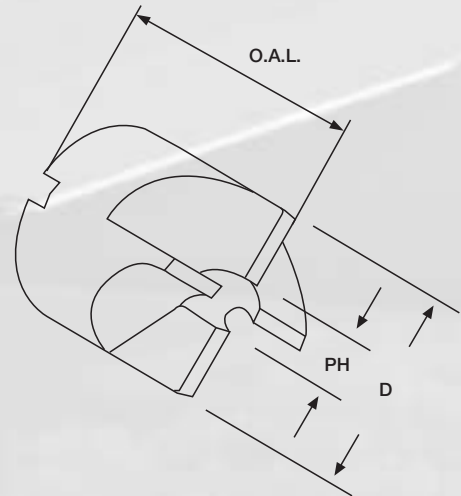

**190 SERIES** reverse spotfacers are designed for use in restricted areas where conventional spotfacers cannot be utilized. Made from the finest high speed tool steel. Cutters are furnished with 1/32 corner radius. Special sizes subject to quotation.

\* For pilot information see 185 Series and 186 Series

† Furnished with "Double Drive" Bayonet Lock



## CARBIDE REVERSE SPOTFACERS



Solid Carbide



Carbide Tipped

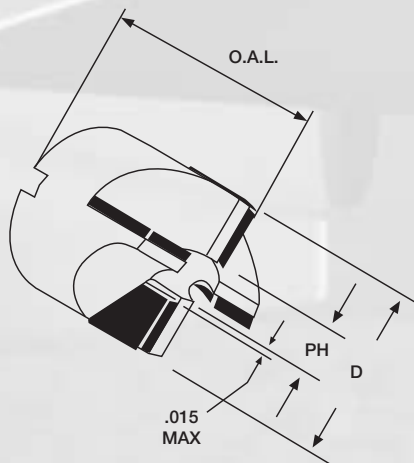

**191 SERIES** carbide reverse spotfacers are similar in design to the 190 Series high speed steel cutters. They excel in cutting highly abrasive materials, the "difficult to machine" materials, and in cutting any material where longer tool life is desired. 186 Series step pilots are recommended for use with carbide tipped cutters as tipped cutters have a maximum non-cutting diameter 1/32 larger than pilot hole, see sketch. All carbide cutters are supplied with 1/64 corner radius. Special sizes subject to quotation.

\* For pilot information see 185 Series and 186 Series.

† Furnished with "Double Drive" Bayonet Lock.

TOOL NUMBER	"D" CUTTER DIA.	"PH" PILOT HOLE	CONSTRUCTION	PILOT REF.*		OAL
				PLAIN PILOT	STEP PILOT	
191-1J	1/4	3/32	Solid Carbide	185-1	186-1	1/2
191-1K	1/4	1/8	Solid Carbide	185-2	186-2	1/2
191-2J	5/16	3/32	Solid Carbide	185-1	186-1	1/2
191-2K	5/16	1/8	Solid Carbide	185-2	186-2	1/2
191-2L	5/16	5/32	Solid Carbide	185-3	186-3	1/2
191-3J	3/8	1/8	Solid Carbide	185-2	186-2	1/2
191-3K	3/8	5/32	Solid Carbide	185-3	186-3	1/2
191-3L	3/8	3/16	Solid Carbide	185-4	186-4	1/2
191-4J	7/16	1/8	Solid Carbide	185-2	186-2	1/2
191-4K	7/16	5/32	Solid Carbide	185-3	186-3	1/2
191-4L	7/16	3/16	Solid Carbide	185-4	186-4	1/2
191-5J	1/2	5/32	Solid Carbide	185-3	186-3	1/2
191-5K	1/2	3/16	Solid Carbide	185-4	186-4	1/2
191-5L	1/2	1/4	Solid Carbide	185-5	186-5	1/2
191-6J	9/16	5/32	Solid Carbide	185-3	186-6	5/8
191-6K	9/16	3/16	Solid Carbide	185-4	186-7	5/8
191-6L	9/16	1/4	Solid Carbide	185-5	186-8	5/8
191-7J	5/8	3/16	Solid Carbide	185-4	186-7	5/8
191-7K	5/8	1/4	Solid Carbide	185-5	186-8	5/8
191-7L	5/8	5/16	Solid Carbide	185-6	186-9	5/8
191-8J	11/16	3/16	Solid Carbide	185-4	186-7	5/8
191-8K	11/16	1/4	Solid Carbide	185-5	186-8	5/8
191-8L	11/16	5/16	Solid Carbide	185-6	186-9	5/8
191-9J	3/4	1/4	Solid Carbide	185-5	186-8	5/8
191-9K	3/4	5/16	Solid Carbide	185-6	186-9	5/8
191-9L	3/4	3/8	Solid Carbide	185-7	186-10	5/8
191-10J	7/8	1/4	Solid Carbide	185-5	186-8	5/8
191-10K	7/8	5/16	Solid Carbide	185-6	186-9	5/8
191-10L	7/8	3/8	Solid Carbide	185-7	186-10	5/8
191-11J	1	5/16	Solid Carbide	185-6	186-9	5/8
191-11K	1	3/8	Solid Carbide	185-7	186-10	5/8
191-11L	1	1/2	Solid Carbide	185-8	186-11	5/8
191-11M	1-1/8	3/8	Carbide Tipped		186-14	7/8
191-11N	1-1/8	1/2	Carbide Tipped		186-17	7/8
191-12J	1-1/4	3/8	Carbide Tipped		186-14	7/8
191-12K	1-1/4	1/2	Carbide Tipped		186-17	7/8
191-13J †	1-3/8	5/8	Carbide Tipped		186-20,21	7/8
191-14J †	1-1/2	5/8	Carbide Tipped		186-20,21	7/8
191-15J †	1-5/8	3/4	Carbide Tipped		186-22,23,24	1
191-16J †	1-3/4	3/4	Carbide Tipped		186-22,23,24	1
191-17J †	1-7/8	3/4	Carbide Tipped		186-22,23,24	1
191-18J †	2	3/4	Carbide Tipped		186-22,23,24	1





# 185 SERIES

## PLAIN PILOTS FOR REVERSE COUNTERSINKS & SPOTFACERS

**185 SERIES** plain pilots are designed for use with 180 and 181 Series reverse countersinks and 190 and 191 Series reverse spotfacers. Featuring the popular bayonet lock, these pilots are completely interchangeable among the four reverse cutter series. \* The large pilots (5/8 and 3/4) are furnished with the "double drive" bayonet lock and are 8 inches long overall.

PLAIN PILOT NUMBER	"P" PLAIN PILOT DIAMETER
185-1	3/32
185-2	1/8
185-3	5/32
185-4	3/16
185-5	1/4
185-6	5/16
185-7	3/8
185-8	1/2
185-9*	5/8
185-10*	3/4

\* Furnished with "double drive" bayonet lock.

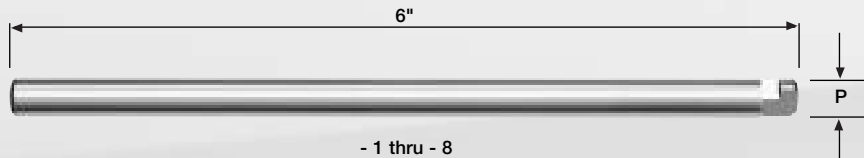

# 186 SERIES

## STEP PILOTS FOR REVERSE COUNTERSINKS & SPOTFACERS

**186 SERIES** step pilots are designed for use with 180 and 181 Series reverse countersinks and 190 and 191 Series reverse spotfacers. These pilots feature a step (larger than the pilot hole in the reverse cutter being used) to pilot in the work piece. Ideal for use with the carbide tipped cutters or where special pilot diameters are required. Special "P2" pilot diameters are readily ground from standard. For proper pilot selection refer to reverse cutter tables. 186-20 thru -24 pilots have the "double drive" bayonet lock, a 2 inch long shank with the same diameter at the "P1" drive, and an overall length of 8 inches. **Pilots with special major diameters smaller than standard are readily ground from standard, prices subject to quotation.**



PILOT NUMBER	"P1" MINOR DIA.	"P2" MAJOR DIA.
186-1	3/32	1/8
186-2	1/8	5/32
186-3	5/32	3/16
186-4	3/16	1/4
186-5	1/4	5/16
186-6	5/32	3/16
186-7	3/16	1/4
186-8	1/4	5/16
186-9	5/16	3/8
186-10	3/8	1/2
186-11	1/2	9/16
186-12	1/4	5/16
186-13	5/16	3/8
186-14	3/8	1/2
186-17	1/2	9/16
186-18	3/8	1/2
186-19	1/2	9/16

PILOT NUMBER	"P1" MINOR DIA.	"P2" MAJOR DIA.
186-20*	5/8	3/4
186-21*	5/8	7/8
186-22*	3/4	7/8
186-23*	3/4	1
186-24*	3/4	1-1/4

\*Furnished with "double drive" bayonet lock.

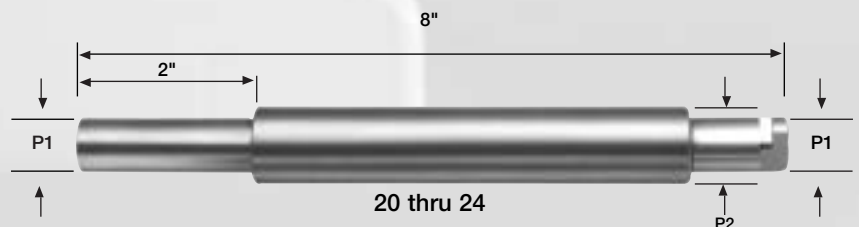



## CUPPED SETS

ORDER BY CATALOG NO. AND DASH NO.



**CATALOG NO.**

CA1000 AN430 RD. HD.

CA1001 AN455 BRAZ. HD.

CA1002 AN470 UNIV. HD.

CA1102 AN450 SEMI. TUB. (UPSET)

USED IN RIVET GUNS IN OPEN AREAS

PRECISION GROUND SHANKS, CLOSE TOLERANCE CUPS

DASH NO.						
L	1/16 RIV	3/32 RIV	1/8 RIV	5/32 RIV	3/16 RIV	1/4 RIV
2-1/2	-026	-26	-27	-28	-29	-30
3-1/2	-01	-1	-6	-11	-16	-21
5-1/2	-02	-2	-7	-12	-17	-22
7-1/2	-03	-3	-8	-13	-18	-23
10-1/2	-04	-4	-9	-14	-19	-24
13-1/2	-05	-5	-10	-15	-20	-25

ALSO AVAILABLE IN 7/32 AN470 AND OTHER SPECIAL SIZES

## FLUSH SETS

ORDER BY CATALOG NO. AND DASH NO.

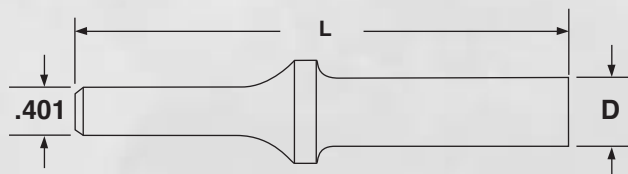

**CATALOG NO.**

CA1020 AN426 FLUSH

USED IN FLUSH RIVETS IN OPEN AREAS

DASH NO.		
L	1/2 D	5/8 D
2-1/2	-26	-29
3-1/2	-1	-16
5-1/2	-2	-17
7-1/2	-3	-18
10-1/2	-4	-19
13-1/2	-5	-20

SEE PRICE LIST FOR STANDARD ITEMS



# OFFSET RIVET SETS .401 SHANK

## CUPPED SETS

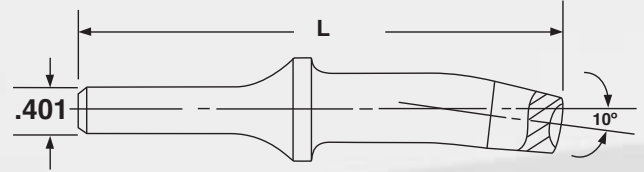

**CATALOG NO.**

CA1003 AN430 RD. HD.

CA1004 AN455 BRAZ. HD.

CA1005 AN470 UNIV. HD.

**ORDER BY CATALOG NO. AND DASH NO.**

**USED IN RIVET GUNS IN RESTRICTED AREAS**

DASH NO.					
L	3/32 RIV	1/8 RIV	5/32 RIV	3/16 RIV	1/4 RIV
3-1/2	-1	-6	-11	-16	-21
5-1/2	-2	-7	-12	-17	-22
7-1/2	-3	-8	-13	-18	-23
10-1/2	-4	-9	-14	-19	-24
13-1/2	-5	-10	-15	-20	-25

**SPECIAL SIZES MANUFACTURED TO SPECIFICATIONS**

## FLUSH SETS



**ORDER BY CATALOG NO. AND DASH NO.**

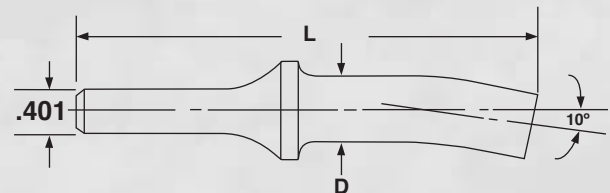

**CATALOG NO.**

CA1021 AN426 FLUSH

**USED ON FLUSH RIVETS IN RESTRICTED AREAS**

DASH NO.		
L	1/2 D	5/8 D
3-1/2	-1	-16
5-1/2	-2	-17
7-1/2	-3	-18
10-1/2	-4	-19
13-1/2	-5	-20

**SEE PRICE LIST FOR STANDARD ITEMS**

# STRAIGHT RIVET SETS .498 SHANK



## CUPPED SETS

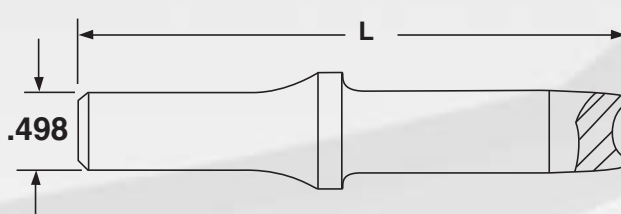

CATALOG NO.  
 CA1006 AN430 RD. HD.  
 CA1007 AN455 BRAZ. HD.  
 CA1008 AN470 UNIV. HD.

ORDER BY CATALOG NO. AND DASH NO.  
 FOR USE IN LARGER RIVET GUNS ON LARGER RIVETS

DASH NO.		
L	3/16 RIV	1/4 RIV
3-1/2	-16	-21
5-1/2	-17	-22
7-1/2	-18	-23
10-1/2	-19	-24
13-1/2	-20	-25

## FLUSH SETS

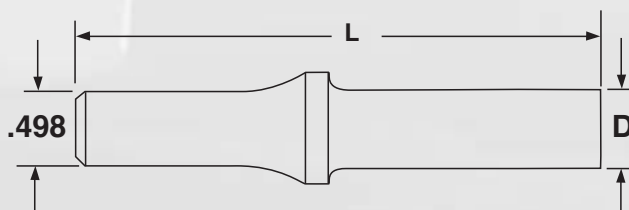

CATALOG NO.  
 CA1020 AN426 FLUSH HD

ORDER BY CATALOG NO. AND DASH NO.

DASH NO.	
L	5/8 D
3-1/2	-16
5-1/2	-17
7-1/2	-18
10-1/2	-19
13-1/2	-20

## BELL CUPPED SETS

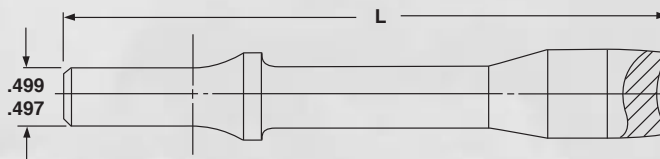

CATALOG NO.  
 CA1012 AN430 RD. HD.  
 CA1013 AN455 BRAZ. HD.  
 CA1014 AN470 UNIV. HD.

ORDER BY CATALOG NO. AND DASH NO.  
 USED IN FLUSH RIVETS IN OPEN AREAS

DASH NO.			
L	1/4 RIV	5/16 RIV	3/8 RIV
5-1/2	-1	-4	-7
7-1/2	-2	-5	-8
10-1/2	-3	-6	-9

SEE PRICE LIST FOR STANDARD ITEMS



# OFFSET RIVET SETS .498 SHANK

## CUPPED SETS

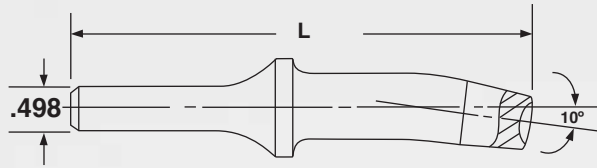

CATALOG NO.  
 CA1009 AN430 RD. HD.  
 CA1010 AN455 BRAZ. HD.  
 CA1011 AN470 UNIV. HD.

ORDER BY CATALOG NO. AND DASH NO.  
 FOR USE IN LARGER RIVET GUNS ON LARGER RIVETS

DASH NO.		
L	3/16 RIV	1/4 RIV
3-1/2	-16	-21
5-1/2	-17	-22
7-1/2	-18	-23
10-1/2	-19	-24
13-1/2	-20	-25

## FLUSH SETS

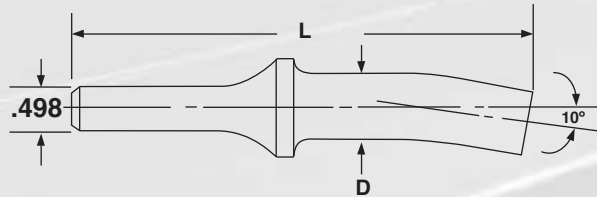

CATALOG NO.  
 CA1023 AN426 FLUSH HD.

ORDER BY CATALOG NO. AND DASH NO.

DASH NO.	
L	5/8 D
3-1/2	-16
5-1/2	-17
7-1/2	-18
10-1/2	-19
13-1/2	-20

## BELL CUPPED SETS

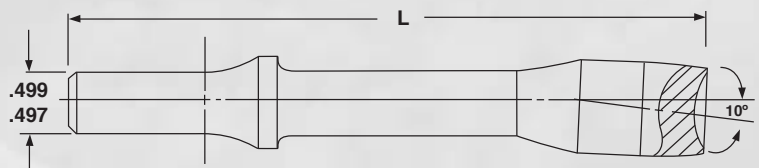

CATALOG NO.  
 CA1015 AN430 RD. HD.  
 CA1016 AN455 BRAZ. HD.  
 CA1017 AN470 UNIV. HD.

ORDER BY CATALOG NO. AND DASH NO.  
 FOR USE IN LARGER RIVET GUNS ON LARGER RIVETS

DASH NO.			
L	1/4 RIV	5/16 RIV	3/8 RIV
5-1/2	-1	-4	-7
7-1/2	-2	-5	-8
10-1/2	-3	-6	-9

SEE PRICE LIST FOR STANDARD ITEMS



## STRAIGHT FLUSH SETS



CATALOG NO.  
CA1018 .401 DIA.  
CA1018A .498 SHANK DIA.

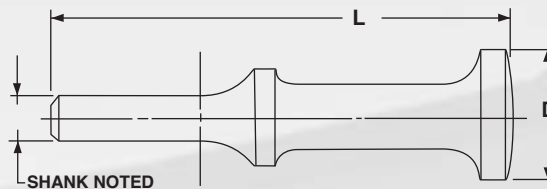

USED FOR DRIVING FLUSH RIVETS WHERE  
A SMOOTH SKIN IS ESSENTIAL

## OFFSET FLUSH SETS



CATALOG NO.  
CA1031 .401 DIA.  
CA1031A .498 SHANK DIA.  
ORDER BY CATALOG NO. AND DASH NO.

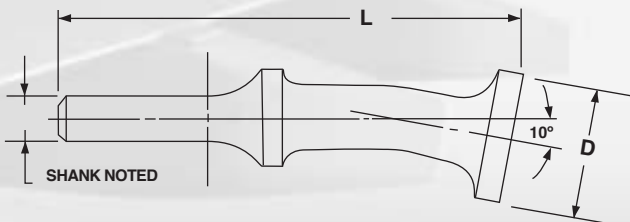

DASH NO.			
L	3/4 D	1" D	1 1/4 D
3-1/2	-1	-4	-7
5-1/2	-2	-5	-8
7-1/2	-3	-6	-9

## MUSHROOM FLUSH SETS



CATALOG NO.  
CA1019 .401 SHANK DIA.  
CA1019A .498 SHANK DIA.  
ORDER BY CATALOG NO. AND DASH NO.

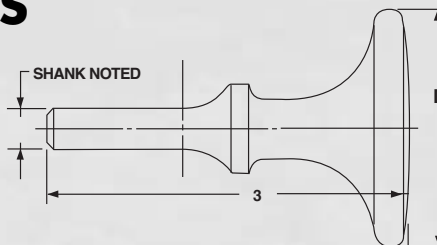

SPECIALLY DESIGNED FOR FLUSH RIVETING  
THIN SKINS WITHOUT DANGER OF DAMAGE  
TO THE FLAT SURFACE

D	DASH NO.
1-1/2	-1
2	-2

## STUBBY FLUSH SETS



CA1030 .401 SHANK DIA  
CA1016 .498 SHANK DIA  
ORDER BY CATALOG NO. AND DASH NO.

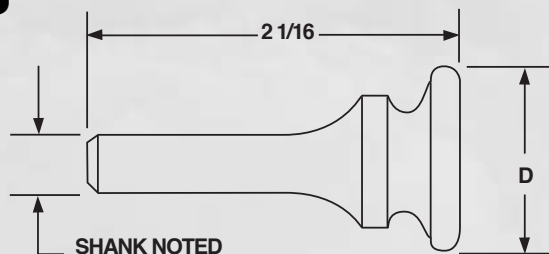

D	DASH NO.
3/4	-1
1	-2
1-1/4	-3

SEE PRICE LIST FOR STANDARD ITEMS





# RIVET SETS

## CORNER GUN SETS

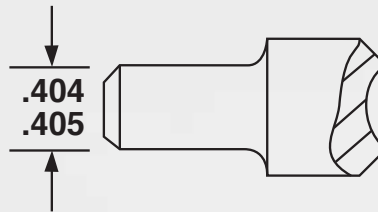
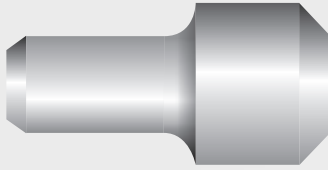

CUPPED / FLUSH

FOR USE IN RESTRICTED AREAS IN CP459 RIVET GUNS

CALL FOR INFORMATION ON STOCK ITEMS

## DOUBLE OFFSET RIVET SET

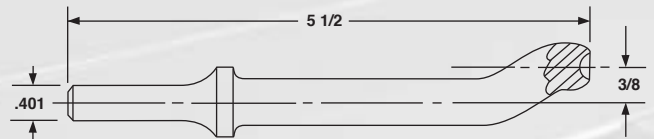

CATALOG NO.

CA1060 AN430 RD. HD.

CA1061 AN455 BRAZ. HD.

CA1062 AN470 UNIV HD.

CA1064 FLUSH HEAD

ORDER BY CATALOG NO. AND DASH NO.

FOR USE IN RESTRICTED AREAS

RIVET SIZE	DASH NO.
3/32	-1
1/8	-2
5/32	-3
3/16	-4



CATALOG NO.

CA1050 SWIVEL SETS

CA1051 DOUBLE OFFSET SWIVEL SETS



CATALOG NO.

CA1065 GOOSENECK SET

CA1066 GOOSENECK SET

CA1067 GOOSENECK SET

CA1068 GOOSENECK SET

CA1069 GOOSENECK SET

CALL FOR INFORMATION ON THESE SETS

SEE PRICE LIST FOR STANDARD ITEMS

# SHORT SHANK FLUSH RIVET SETS



## STRAIGHT FLUSH

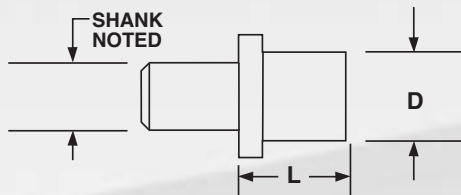

CATALOG NO.

CA1300 .401 SHANK DIA.

CA1300A .498 SHANK DIA.

ORDER BY CATALOG NO. AND DASH NO.

D	L	DASH NO.
3/8	21/32	-1
1/2	21/32	-2
5/8	21/32	-3

## OFFSET FLUSH

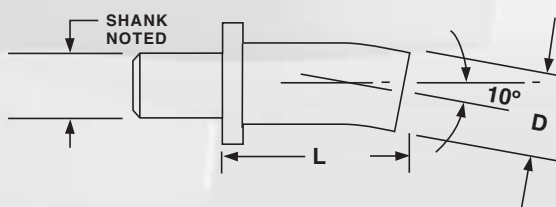

CATALOG NO.

CA1305 .401 SHANK DIA.

CA1305A .498 SHANK DIA.

D	L	DASH NO.
3/8	1-1/8	-1
1/2	1-1/8	-2
5/8	1-1/8	-3

## STRAIGHT CUPPED

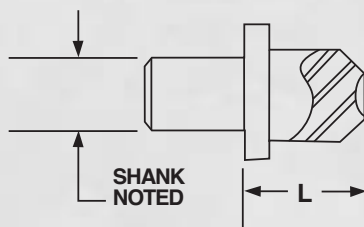

CATALOG NO.

CA1310 .401 SHANK DIA.

CA1310A .498 SHANK DIA.

D	L	DASH NO.
1/16 AN470	21/32	-1
3/32 AN470	21/32	-2
1/8 AN470	21/32	-3
5/32 AN470	21/32	-4
3/16 AN470	21/32	-5
1/4 AN470	21/32	-6

## OFFSET CUPPED

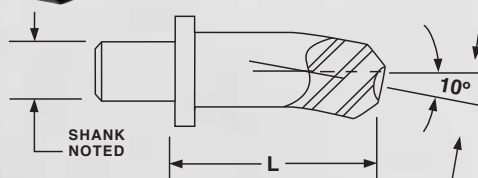

CATALOG NO.

CA1315 .401 SHANK DIA.

CA1315A .498 SHANK DIA.

D	L	DASH NO.
1/16 AN470	1-1/8	-1
3/32 AN470	1-1/8	-2
1/8 AN470	1-1/8	-3
5/32 AN470	1-1/8	-4
3/16 AN470	1-1/8	-5
1/4 AN470	1-1/8	-6

SEE PRICE LIST FOR STANDARD ITEMS



# RIVET SET SHANKS STANDARD AN RIVETS

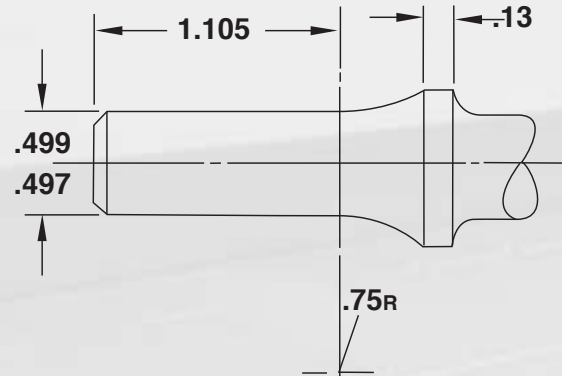
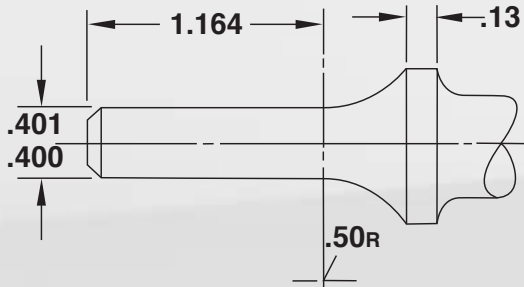
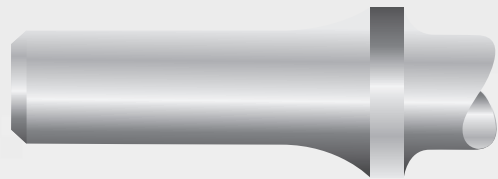
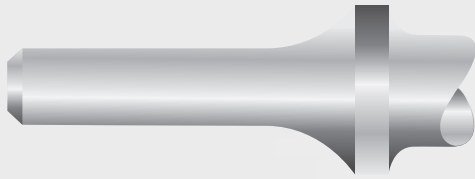

1/6 RIVET MIN., 1/4 RIVET MAX.

5/32 RIVET MIN., 3/8 RIVET MAX.

THE ABOVE RIVET SET SHANK DIMENSIONS ARE FOR USE IN ALL STANDARD RIVETING HAMMERS

## STANDARD AN RIVETS (FOR INFORMATION ONLY)

AN NO.	RIVET TYPE	
AN-430	ROUND HEAD	
AN-455	BRAZIER HEAD	
AN-470	UNIVERSAL HEAD	
AN-426	100° FLUSH RIVET	



## CUPPED SQUEEZER SETS

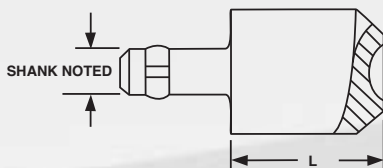

### CATALOG NO.

CA2000	AN430	RD. HD.	.187 SH
CA2000A	AN430	RD. HD.	.250 SH
CA2001	AN455	BRAZ. HD.	.187 SH
CA2001A	AN455	BRAZ. HD.	.250 SH
CA2002	AN470	UNIV. HD.	.187 SH
CA2002A	AN470	UNIV. HD.	.250 SH

DESIGNED FOR USE IN PNEUMATIC AND HAND SQUEEZERS

DASH NO.						
L	1/16 RIV	3/32 RIV	1/8 RIV	5/32 RIV	3/16 RIV	1/4 RIV
1/8	-01X	-1X	-8X	-15X	-22X	-29X
1/4	-01	-1	-8	-15	-22	-29
3/8	-02	-2	-9	-16	-23	-30
1/2	-03	-3	-10	-17	-24	-31
5/8	-04	-4	-11	-18	-25	-32
3/4	-05	-5	-12	-19	-26	-33
7/8	-06	-6	-13	-20	-27	-34
1	-07	-7	-14	-21	-28	-35

ORDER BY CATALOG NO. AND DASH NO.

## CUPPED SETS FOR SEMITUBULAR RIVETS



CA2004 SERIES



CA2005 SERIES

### CATALOG NO.

CA2005	AN450	SEMI-TUB.	.187 SH
CA2005A	AN450	SEMI-TUB.	.250 SH
CA2004	AN456	MOD BRAZ.	.187 SH
CA2004A	AN456	MOD BRAZ.	.250 SH

ORDER BY CATALOG NO. AND DASH NO. ABOVE (CA2000 TABLE)

## CUPPED SETS .312, .375 SHANK

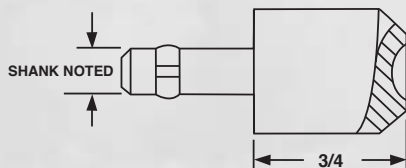
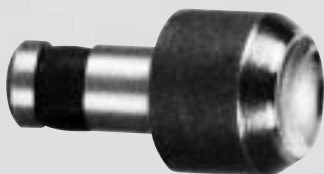

FOR USE IN LARGE RIVET SQUEEZERS

ORDER BY CATALOG NO. AND DASH NO.

### CATALOG NO.

CA2000B	AN430	RD. HD.	.312 SH
CA2000C	AN430	RD. HD.	.375 SH
CA2001B	AN455	BR. HD.	.312 SH
CA2001C	AN455	BR. HD.	.375 SH
CA2002B	AN470	UN. HD.	.312 SH
CA2002C	AN470	UN. HD.	.375 SH

DASH NO.			
3/32 RIV	1/8 RIV	5/32 RIV	3/16 RIV
-5	-12	-19	-26
1/4 RIV	5/16 RIV	3/8 RIV	
-33	-40	-47	

SPECIAL SIZES MANUFACTURED TO SPECIFICATIONS



# FLUSH SQUEEZER SETS

## FLUSH SQUEEZER SETS

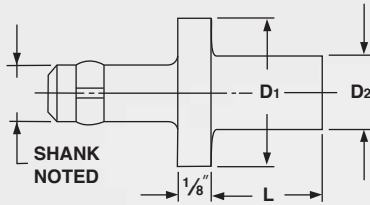
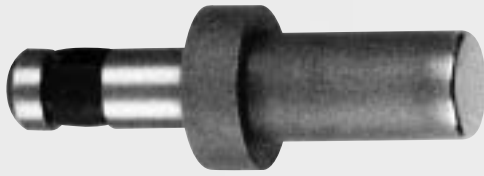

DESIGNED FOR USE IN PNEUMATIC AND HAND SQUEEZERS. THESE SETS HAVE CENTERLESS GROUND SHANKS AND HIGHLY POLISHED WORKING SURFACES. EACH SET IS FURNISHED COMPLETE WITH RETAINER SPRING

**CATALOG NO.**

CA2003 .187 SHANK DIA.

CA2003A .250 SHANK DIA.

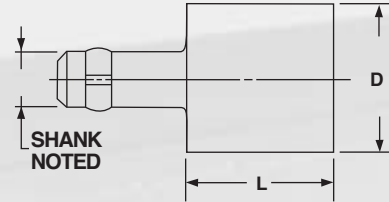
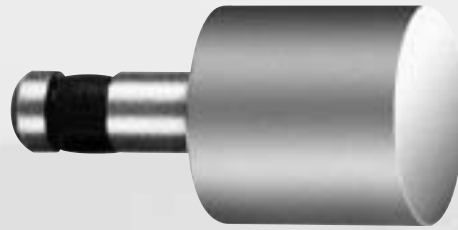

ORDER BY CATALOG NO. AND DASH NO.

D	L	DASH NO.
3/8	1/8	-1
3/8	3/16	-2
3/8	1/4	-3
3/8	5/16	-4
3/8	3/8	-5
3/8	7/16	-6
3/8	1/2	-7
3/8	9/16	-8
3/8	5/8	-9
3/8	11/16	-10
3/8	3/4	-11
3/8	13/16	-12
3/8	7/8	-13
3/8	15/16	-14
3/8	1	-15

D	L	DASH NO.
1/2	1/8	-16
1/2	3/16	-17
1/2	1/4	-18
1/2	5/16	-19
1/2	3/8	-20
1/2	7/16	-21
1/2	1/2	-22
1/2	9/16	-23
1/2	5/8	-24
1/2	11/16	-25
1/2	3/4	-26
1/2	13/16	-27
1/2	7/8	-28
1/2	15/16	-29
1/2	1	-30

D	L	DASH NO.
3/4	1/8	-31
3/4	3/16	-32
3/4	1/4	-33
3/4	5/16	-34
3/4	3/8	-35
3/4	7/16	-36
3/4	1/2	-37
3/4	9/16	-38
3/4	5/8	-39
3/4	11/16	-40
3/4	3/4	-41
3/4	13/16	-42
3/4	7/8	-43
3/4	15/16	-44
3/4	1	-45

D	L	DASH NO.
1	1/8	-46
1	3/16	-47
1	1/4	-48
1	5/16	-49
1	3/8	-50
1	7/16	-51
1	1/2	-52
1	9/16	-53
1	5/8	-54
1	11/16	-55
1	3/4	-56
1	13/16	-57
1	7/8	-58
1	15/16	-59
1	1	-60

D1	D2	L	DASH NO.
3/8	1/4	1/8	-61
3/8	1/4	3/16	-62
3/8	1/4	1/4	-63
3/8	1/4	5/16	-64
3/8	1/4	3/8	-65
3/8	1/4	7/16	-66
3/8	1/4	1/2	-67
3/8	1/4	9/16	-68
3/8	1/4	5/8	-69
3/8	1/4	11/16	-70
3/8	1/4	3/4	-71
3/8	1/4	13/16	-72
3/8	1/4	7/8	-73
3/8	1/4	15/16	-74
3/8	1/4	1	-75

SPECIAL SIZES MANUFACTURED TO SPECIFICATIONS

## FLUSH SETS - .312, .375 SHANK

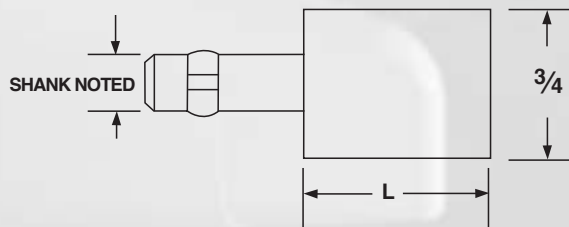
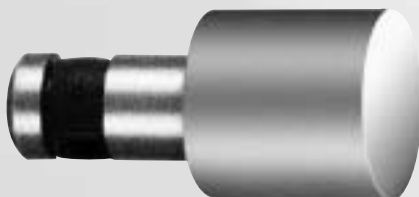

**CATALOG NO.**

CA2003 .312 SHANK

CA2003C .375 SHANK

DASH NO.	L
-37	1/2
-41	3/4
-45	1

FOR USE IN LARGER RIVET SQUEEZERS

# DIMPLING TOOLS/RETAINER SPRINGS



## PUNCH

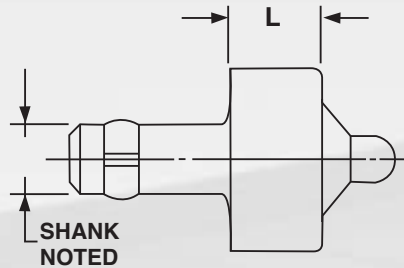

THESE TOOLS ARE DESIGNED FOR THE AN426 - 100° FLUSH RIVET, AND USED IN PNEUMATIC AND HAND SQUEEZERS

CATALOG NO. CA3000 .187 SHANK

DASH NO.				
L	3/32 RIV	1/8 RIV	5/32 RIV	3/16 RIV
1/4	-1	-6	-11	-16
3/8	-2	-7	-12	-17
1/2	-3	-8	-13	-18
5/8	-4	-9	-14	-19
3/4	-5	-10	-15	-20

## DIE

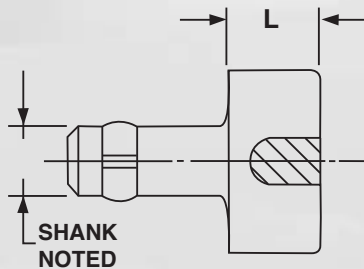
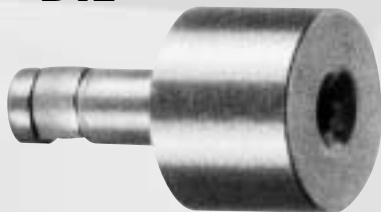

CATALOG NO. CA3001 .187 SHANK

DASH NO.				
L	3/32 RIV	1/8 RIV	5/32 RIV	3/16 RIV
3/8	-1	-5	-9	-13
1/2	-2	-6	-10	-14
5/8	-3	-7	-11	-15
3/4	-4	-8	-12	-26

ORDER BY CATALOG NO. AND DASH NO

## SQUEEZER SET RETAINER SPRINGS



CATALOG NO.  
 CA2601 3/16 SHANK  
 CA2601A 1/4 SHANK  
 CA2601B 5/16 SHANK  
 CA2601C 3/8 SHANK

FOR USE ON RIVET SQUEEZER AND DIMPLE SETS - CA2000 AND CA3000 SERIES





# LONG SERIES AIRCRAFT COUNTERBORES



**LONG SET - FOUR FLUTE  
HIGH SPEED - STRAIGHT SHANK  
INTERCHANGEABLE PILOTS**

**CATALOG NO. CA4014**

DIAMETER	LENGTH OVER-ALL (INCHES)	SHANK SIZE AND LENGTH	FLUTES	PILOT HOLE (INCHES)
3/16	3	15/64 X 2-1/2	4	3/32
7/32	3	15/64 X 2-1/2	4	3/32
1/4	3 3/4	15/64 X 3-1/16	4	3/32
9/32	3 3/4	17/64 X 3-1/8	4	3/32
5/16	3 3/4	19/64 X 3-1/8	4	3/32
11/32	3 3/4	5/16 X 3-1/8	4	3/32
3/8	3 3/4	5/16 X 3-1/8	4	3/32
13/32	4 1/8	5/16 X 3	4	1/8
7/16	4 1/8	5/16 X 3	4	1/8
15/32	4 1/8	7/16 X 3	4	1/8
1/2	4 1/8	7/16 X 3	4	1/8
17/32	4 1/4	7/16 X 3	4	5/32
9/16	4 1/4	7/16 X 3	4	5/32
19/32	4 1/4	1/2 X 3	4	5/32
5/8	4 1/4	1/2 X 3	4	5/32
21/32	5 3/8	1/2 X 4	4	3/16
11/16	5 3/8	1/2 X 4	4	3/16
23/32	5 3/8	1/2 X 4	4	3/16
3/4	5 3/8	1/2 X 4	4	3/16
25/32	5 3/8	1/2 X 4	4	3/16
13/16	5 3/8	1/2 X 4	4	3/16
7/8	5 3/8	1/2 X 4	4	3/16
15/16	5 3/8	1/2 X 4	4	3/16
1	5 3/8	1/2 X 4	4	3/16
1-1/16	5 1/2	3/4 X 4	4	5/16
1-1/8	5 1/2	3/4 X 4	4	5/16
1-3/16	5 1/2	3/4 X 4	4	5/16
1-1/4	5 1/2	3/4 X 4	4	5/16
1-5/16	5 1/2	3/4 X 4	4	5/16
1-3/8	5 1/2	3/4 X 4	4	5/16
1-7/16	5 1/2	3/4 X 4	4	5/16
1-1/2	5 1/2	3/4 X 4	4	5/16

**TO MEET SPECIAL CONDITIONS IN THE AIRCRAFT INDUSTRY, THESE COUNTERBORES HAVE PILOT HOLES SMALLER THAN STANDARD AND ARE ESPECIALLY USEFUL FOR DEEP COUNTERBORING SCREW HEADS AND SPRING POCKETS. ALL COUNTERBORES ARE MADE OF FINEST H. S. STEEL AVAILABLE. SHANKS ARE HARDENED AND GROUND, ASSURING LONG LIFE AND CONCENTRIC OPERATION. FURNISHED WITHOUT RADIUS UNLESS SPECIFIED.**

## BURRING CUTTER

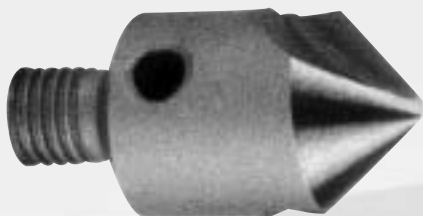

CATALOG NO. CA4475

D	DASH NO.
3/8	-2
1/2	-4

THESE TWO FLUTE CUTTERS ARE FOR USE IN ANGLE DRILLS OR SPEED DRIVERS (CA6005) WITH 1/4 - 28 THREADS

STANDARD INCLUDED ANGLES 82°, 90°, 100°

ORDER BY CATALOG NO., DASH NO. AND ANGLE

## COUNTERSINK EXTENSIONS

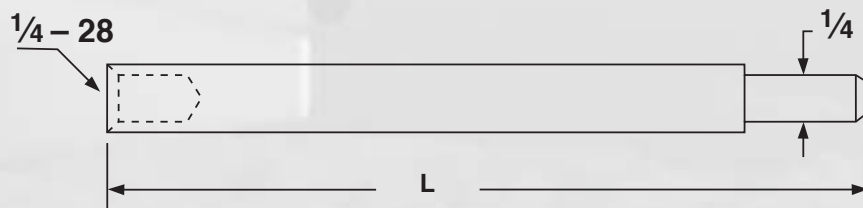

CATALOG NO. CA4500

L	DASH NO.
4"	-1
6"	-2
12"	-3

FOR USE WITH 1/4 - 28 SHANK COUNTERSINKS AND CUTTERS

ORDER BY CATALOG NO., DASH NO. AND ANGLE

## SPEED DRIVER



CATALOG NO. CA6005

USED WITH CA4475 CUTTERS TO RAPIDLY DEBURR HOLES



## DRILLS AND REAMERS

### AIRCRAFT EXTENSION DRILLS

EXPEDITED SERVICE ON YOUR TOOLS OR OURS  
SPECIAL LENGTHS OF DRILLS, TAPS, AND REAMERS FURNISHED  
TO YOUR SPECIFICATIONS. CAN EXTEND YOUR TOOLS OR OURS.



CATALOG NO.  
CA4700A — 6"  
CA4700B — 12"

3/64 THRU 1/2
A THRU Z
#1 THR #60

ORDER BY CATALOG NO. AND SIZE

FURNISHED IN 6" AND 12" LENGTHS FOR USE IN DRILLING  
HOLES IN REMOTE, HARD-TO-REACH LOCATIONS.

AOG SERVICE AVAILABLE

### THREADED SHANK AIRCRAFT DRILLS



CATALOG NO. CA4705

ORDER BY CATALOG NO., LENGTH, THREAD, AND SIZE

LENGTHS: SHORT SERIES  
LONG SERIES  
EXTRA SHORT  
THREAD: 5 - 40, 10 - 32, 1/4 - 28  
SIZE RANGE: #1 TO #50  
1/16 TO 3/8  
A TO W

FOR USE IN ALL TYPES OF ANGLE AND FLEXIBLE  
DRIVE DRILLING ATTACHMENTS.

### PILOTED DRILLS AND REAMERS



(SHOWN WITH OPTIONAL ADAPTER)

CATALOG NO.  
CA4710 PILOTED DRILLS  
CA4715 PILOTED REAMERS

PRECISION GROUND PILOTS ON YOUR TOOLS OR OURS.

ORDER BY CATALOG NO., TOOL DIA. S, PILOT DIA. P, AND LENGTH L.



## SET SCREW DRILL ADAPTERS

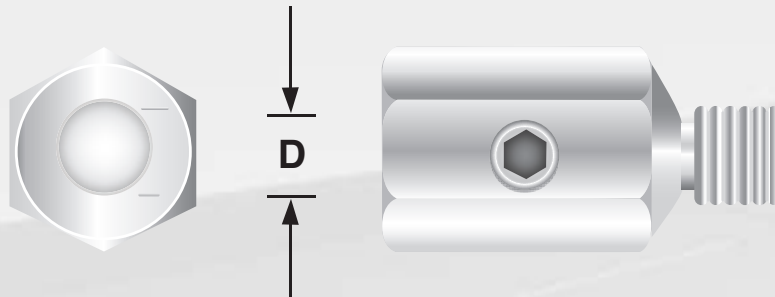

**CATALOG NO.**

CA5000 10-32 THD. SHANK  
 CA5000A 1/4-28 THD. SHANK

**ORDER BY CATALOG AND DRILL SIZE "D"**  
 DESIGNED FOR USE IN ALL TYPES OF ANGLE DRILLS  
 AND FLEXIBLE SHAFTS

**SIZES 10, 21, 30, 40, 3/32, 1/8, 5/32, 3/16**  
 OTHER SIZES AVAILABLE

## DUPLICATING PUNCHES



**ORDER BY CATALOG NO. AND DASH NO.**

**SEE PRICE SHEET FOR STANDARD SIZES**

**CATALOG NO. CA5002**

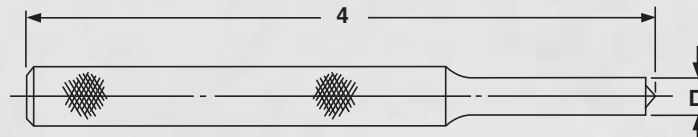

SIZE	D	DASH NO.
1/16	.0625	-1
#50	.070	-2
3/32	.0937	-3
#40	.098	-4
1/8	.125	-5
#30	.1285	-6
#29	.136	-7
9/64	.1406	-8
5/32	.1562	-9

SIZE	D	DASH NO.
#21	.159	-9A
#20	.161	-10
#19	.166	-11
11/64	.1719	-12
3/16	.1875	-13
#10	.1935	-14
13/64	.2031	-15
#5	.2055	-16
7/32	.2187	-17

SIZE	D	DASH NO.
15/64	.2344	-18
1/4E	.250	-19
F	.257	-20
17/64	.2656	-21
9/32	.2812	-22
19/64	.2969	-23
5/16	.3125	-24
P	.323	-25
21/64	.3281	-26

SIZE	D	DASH NO.
11/32	.3437	-27
23/64	.3594	-28
3/8	.375	-29
25/64	.3906	-30
13/32	.4062	-31
27/64	.4219	-32
7/16	.4375	-33
29/64	.4531	-34
15/32	.4687	-35

SIZE	D	DASH NO.
31/64	.4843	-36
1/2	.500	-37
9/16	.5625	-38
5/8	.625	-39
11/16	.6875	-40
3/4	.750	-41
13/16	.8125	-42
7/8	.875	-43
15/16	.9375	-44
1"	1.000	-45



## HAND RIVET SQUEEZER

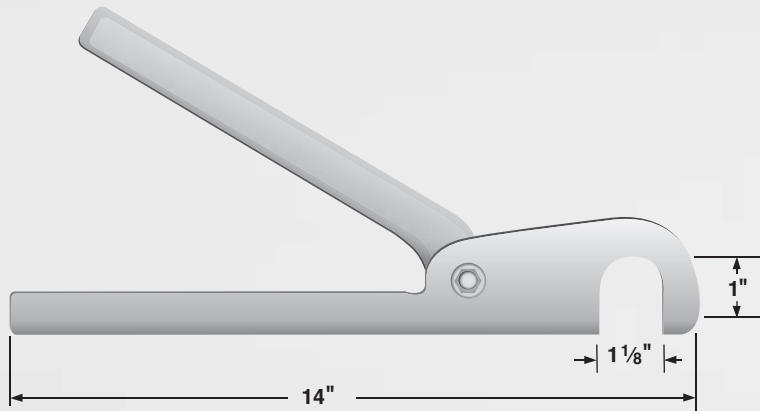

CATALOG NO.  
CA5020

CLOSED HEIGHT 3/4

USED FOR HAND RIVETING AND DIMPLING

FOR SETS SEE CA2000 / CA3000

## RETAINER SPRINGS



CATALOG NO.  
CA5025

USED TO HOLD RIVET SETS IN RIVET GUNS

ORDER BY CATALOG NO. AND MODEL RIVET GUN TO BE USED

## RIVET GUNS



CATALOG NO.  
CA5100

DASH NO.	RIVET CAPACITY		RIVET SET SH	SIMILAR TO
	DURAL	STEEL		
-1	1/8	3/32	.401	CP2X
-2	3/16	5/32	.401	CP3X
-3	1/4	3/16	.401	CP4X
-4	1/4	3/16	.498	CP5X
-5	5/16	1/4	.498	CP9X
-6	3/8	5/16	.498	CP7X

ORDER BY CATALOG NO. AND DASH NO.

PLEASE SPECIFY HANDLE DESIRED  
CAN BE FURNISHED NEW OR RECONDITIONED  
SEE CA1000 SERIES FOR RIVET SETS

## SHEET FASTENERS "CLECOS"



**CATALOG NO.**

CA6010 0 - 1/4 MATERIAL CAPACITY

CA6011 0 - 1/2 MATERIAL CAPACITY

STANDARD SIZES
1/16, 3/32, 1/8, 5/32, 3/16, 1/4

USED TO TEMPORARILY HOLD TWO SHEETS OF MATERIAL TOGETHER

ORDER BY CATALOG NO. AND SIZE

## SHEET FASTENERS PLIERS



"CLECO PLIERS"

CATALOG NO. CA6018

## DRILL STOPS

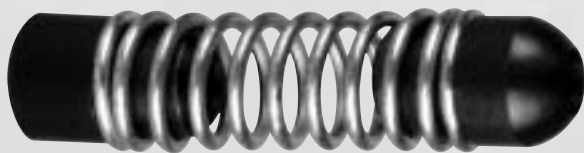

STANDARD SIZES
#40, #30, #21, #10, 1/4, F

DESIGNED AS DRILL STOP AND TO CUSHION BREAK-THRU OF DRILL

SPECIAL SIZES MANUFACTURED





# STRAP DUPLICATORS

## SPRING TYPE

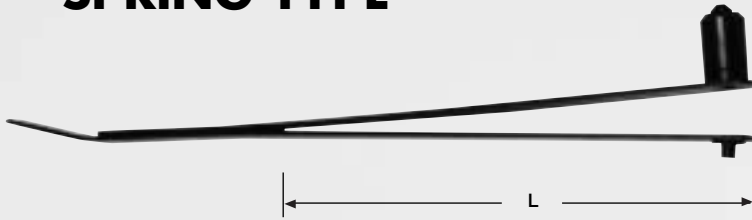

CATALOG NO.

CA6000 L = 6-1/4

CA6000A L = 13-1/4

SPRING LOADED PIN MARKS SHEET STOCK FROM HIDDEN HOLE

DASH NO.	SIZE
-1	#40
-2	#30
-3	#21
-4	#19
-5	#10
-6	#5
-7	F
-8	1/4

ORDER BY CATALOG NO. AND DASH NO.

## BUSHING TYPE

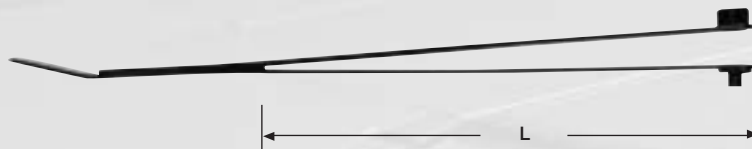

CATALOG NO.

CA6001 L = 6-1/4

CA6001A L = 13-1/4

USE DRILL THROUGH BUSHING WHEN PILOT IS IN HIDDEN HOLE

DASH NO.	SIZE
-1	#40
-2	#30
-3	#21
-4	#19
-5	#10
-6	#5
-7	F
-8	1/4

ORDER BY CATALOG NO. AND DASH NO.

## BUSHING TYPE INVERTED



CATALOG NO.

CA6002 L = 6-1/4

CA6002A L = 13-1/4

SAME AS CA6001 EXCEPT INVERTED PILOT

DASH NO.	SIZE
-1	#40
-2	#30
-3	#21
-4	#19
-5	#10
-6	#5
-7	F
-8	1/4

ORDER BY CATALOG NO. AND DASH NO.

# H49P SERIES



## A.N.D. 10050 & MS 33649 PORT CONTOUR CUTTERS

High speed steel, integral plain pilot series

**H49P SERIES** port tools profile the A.N.D. 10050 or MS 33649 contour. This cutter features the economical, integral plain pilot construction, which makes it desirable for short runs and prototype work.

Made from high speed steel, its short, sturdy construction performs well in highly abrasive materials, and in both ferrous and non-ferrous materials. Like the H49 series, this port tool may be used in a wide range of machinery and equipment not suitable for carbide's high rigidity and high horse power requirements.

All cutting edges are form relieved and all flutes cut the entire form to provide balance, distribution of chip load, maximum tool life between grinds, and ease of sharpening. The flutes are ground into, but do not pass through the integral plain pilot. This provides a better pilot bearing surface and protects the tap drill diameter in the work piece. A slight positive axial rake provides shear action, preventing buildup on the cutting edges and reducing cutting pressures.

Modifications of standard tools are readily available. Special cutter, manufactured to customer's specifications, are given prompt attention.

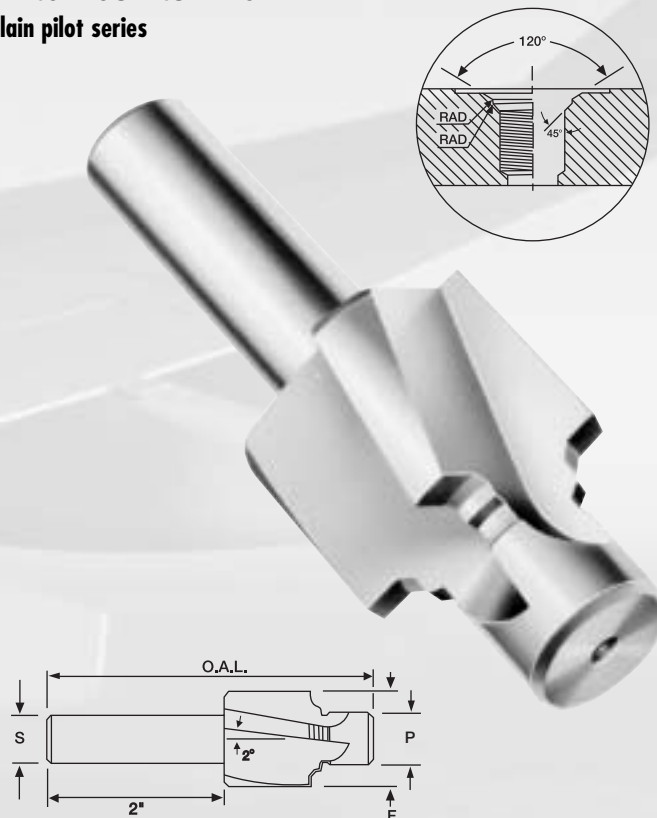

TOOL NUMBER	TUBING O.D.	THREAD SIZE	"PILOT DIAMETER"		"F" SPOTFACE DIAMETER	"S" SHANK DIAMETER	"O.A.L." OVERALL LENGTH	NUMBER OF FLUTES
			A.N.D. 10050	M.S. 33649				
H49P-2	1/8	5/16-24	.270	.274	.742	.500	3-15/32	3
H49P-3	3/16	3/8-24	.332	.338	.805	.500	3-15/32	3
H49P-4	1/4	7/16-20	.385	.392	.888	.500	3-15/32	4
H49P-5	5/16	1/2-20	.448	.454	.950	.500	3-17/32	4
H49P-6	3/8	9/16-18	.505	.511	1.012	.500	3-17/32	4
H49P-7*	7/16	5/8-18	—	.574	1.105	.500	3-3/4	4
H49P-8	1/2	3/4-16	.686	.692	1.240	.500	3-3/4	4
H49P-9*	9/16	13/16-16	—	.755	1.302	.750	4-1/32	4
H49P-10	5/8	7/8-14	.801	.809	1.415	.750	4-1/32	4
H49P-11*	11/16	1-12	—	.924	1.602	.750	4-9/32	4
H49P-12	3/4	1-1/16-12	.975	.986	1.665	.750	4-9/32	4
H49P-14*	7/8	1-3/16-12	—	1.111	1.790	.750	4-5/16	4
H49P-16	1	1-5/16-12	1.225	1.236	1.965	.750	4-5/16	4
H49P-18*	1-1/8	1-1/2-12	—	1.424	2.090	.750	4-11/32	4
H49P-20	1-1/4	1-5/8-12	1.537	1.549	2.310	.750	4-11/32	4
H49P-24*	1-1/2	1-7/8-12	1.787	1.799	2.600	.750	4-1/2	4
H49P-28*	1-3/4	2-1/4-12	2.162	2.174	3.050	1.000	4-3/4	4
H49P-32*	2	2-1/2-12	2.413	2.424	3.520	1.000	4-7/8	4

\* Subject to quote

**Explanation of pilot sizes for all Craig Port Contour cutters.** On plain pilot tools, pilot diameter size is based upon piloting in the proper hole. This hole, in order to meet applicable Mil. Spec. should be sized according to the mean of the min-max tolerance on the minor diameter of the specifications. The common practice of using a standard drill without reaming and/or referring to tap drill charts, cannot be followed since, in most cases, there are no standard drills which produce holes sizes that will meet the Mil. Spec. tolerance on minor diameters.



# H49R SERIES

## A.N.D. 10050 & MS 33649 PORT CONTOUR CUTTERS

High speed steel, reamer pilot series

**H49R SERIES** port tools profile the A.N.D. 10050 or MS 33649 contour. This cutter features the economical, integral reamer pilot construction, which makes it desirable for short runs and prototype work. The reamer pilot sizes the minor diameter per the applicable thread specification.

Made from high speed steel, its short, sturdy construction performs well in highly abrasive materials, and in both ferrous and non-ferrous materials. Like the H49 series, this port tool may be used in a wide range of machinery and equipment not suitable for carbide's high rigidity and high horse power requirements.

All cutting edges are form relieved and all flutes cut the entire form to provide balance, distribution of chip load, maximum tool life between grinds, and ease of sharpening. A slight positive axial rake provides shear action, preventing buildup on the cutting edges and reducing cutting pressures.

Modifications of standard tools are readily available. Special cutter, manufactured to customer's specifications, are given prompt attention.

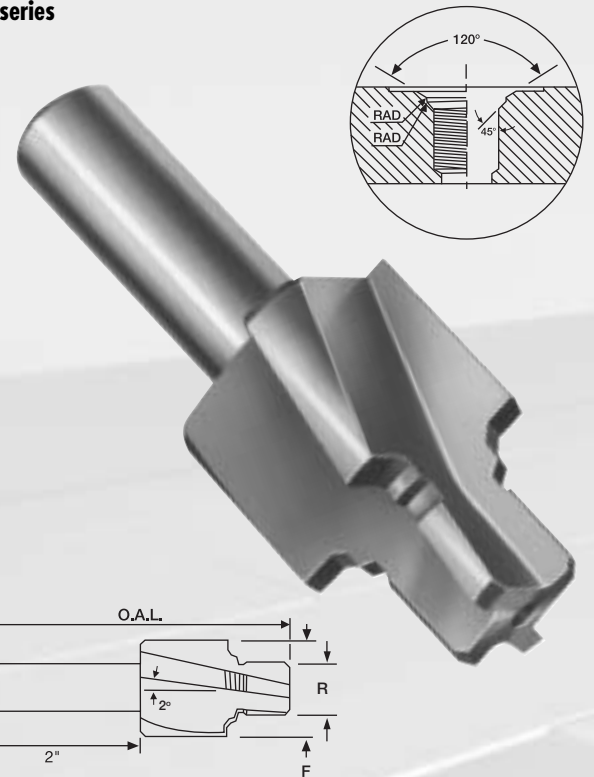

TOOL NUMBER	TUBING O.D.	THREAD SIZE	"PILOT DIAMETER"		"F" SPOTFACE DIAMETER	"S" SHANK DIAMETER	"O.A.L." OVERALL LENGTH	NUMBER OF FLUTES
			A.N.D. 10050	M.S. 33649				
H49R-2	1/8	5/16-24	.271	.275	.742	.500	3-19/32	3
H49R-3	3/16	3/8-24	.333	.339	.805	.500	3-19/32	3
H49R-4	1/4	7/16-20	.386	.393	.888	.500	3-21/32	4
H49R-5	5/16	1/2-20	.449	.455	.950	.500	3-21/32	4
H49R-6	3/8	9/16-18	.506	.512	1.012	.500	3-11/16	4
H49R-7*	7/16	5/8-18	-	.575	1.105	.500	3-15/16	4
H49R-8	1/2	3/4-16	.687	.693	1.240	.500	3-15/16	4
H49R-9*	9/16	13/16-16	-	.756	1.302	.750	4-7/32	4
H49R-10	5/8	7/8-14	.802	.810	1.415	.750	4-7/32	4
H49R-11*	11/16	1-12	-	.925	1.602	.750	4-1/2	4
H49R-12	3/4	1-1/16-12	.976	.987	1.665	.750	4-1/2	4
H49R-14*	7/8	1-3/16-12	-	1.112	1.790	.750	4-1/2	4
H49R-16	1	1-5/16-12	1.226	1.237	1.965	.750	4-1/2	4
H49R-18*	1-1/8	1-1/2-12	-	1.425	2.090	.750	4-9/16	4
H49R-20*	1-1/4	1-5/8-12	1.538	1.550	2.310	.750	4-9/16	4
H49R-24*	1-1/2	1-7/8-12	1.788	1.800	2.600	.750	4-11/16	4
H49R-28*	1-3/4	2-1/4-12	2.163	2.175	3.050	1.000	5	4
H49R-32*	2	2-1/2-12	2.414	2.425	3.520	1.000	5-1/8	4

\* Subject to quote

**Explanation of pilot sizes for all Craig Port Contour cutters.** On the reamer pilot tools the reamer diameter is approximately the mean diameter. This hole, in order to meet applicable Mil. Spec. should be sized according to the mean of the min-max tolerance on the minor diameter of the specifications. The common practice of using a standard drill without reaming and/or referring to tap drill charts, cannot be followed since, in most cases, there are no standard drills which produce hole sizes that will meet the Mil. Spec. tolerance on minor diameters.



## A.N.D. 10050 & MS 33649 PORT CONTOUR CUTTERS

Carbide tipped, integral plain pilot, short series



**49P SERIES** carbide port tools profile the A.N.D. 10050 or MS33649 contour. Form relief ground between centers to ensure concentricity, one piece carbide tips, and short body integral pilot construction combine to make an economical tool suitable for short runs or prototype work where end piloting is required.

Modifications of standard tools are readily available. Special cutters, manufactured to customer's specifications, are given prompt attention.

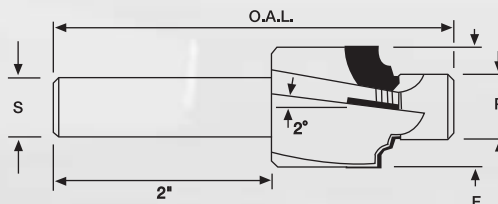
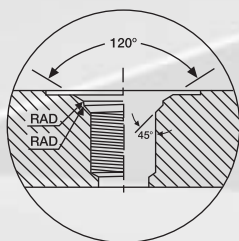

TOOL NUMBER	TUBING O.D.	THREAD SIZE	"PILOT DIAMETER"		"F" SPOTFACE DIAMETER	"S" SHANK DIAMETER	"O.A.L." OVERALL LENGTH	NUMBER OF FLUTES
			A.N.D. 10050	M.S. 33649				
49P-2	1/8	5/16-24	.270	.274	.742	.500	3-15/32	3
49P-3	3/16	3/8-24	.332	.338	.805	.500	3-15/32	3
49P-4	1/4	7/16-20	.385	.392	.888	.500	3-15/32	4
49P-5	5/16	1/2-20	.448	.454	.950	.500	3-17/32	4
49P-6	3/8	9/16-18	.505	.511	1.012	.500	3-17/32	4
49P-7*	7/16	5/8-18	—	.574	1.105	.500	3-3/4	4
49P-8	1/2	3/4-16	.686	.692	1.240	.500	3-3/4	4
49P-9*	9/16	13/16-16	—	.755	1.302	.750	4-1/32	4
49P-10	5/8	7/8-14	.801	.809	1.415	.750	4-1/32	4
49P-11*	11/16	1-12	—	.924	1.602	.750	4-9/32	4
49P-12	3/4	1-1/16-12	.975	.986	1.665	.750	4-9/32	4
49P-14*	7/8	1-3/16-12	—	1.111	1.790	.750	4-5/16	4
49P-16	1	1-5/16-12	1.225	1.236	1.965	.750	4-5/16	4
49P-18*	1-1/8	1-1/2-12	—	1.424	2.090	.750	4-11/32	4
49P-20*	1-1/4	1-5/8-12	1.537	1.549	2.310	.750	4-11/32	4
49P-24*	1-1/2	1-7/8-12	1.787	1.799	2.600	.750	4-1/2	4
49P-28*	1-3/4	2-1/4-12	2.162	2.174	3.050	1.000	4-3/4	4
49P-32*	2	2-1/2-12	2.413	2.424	3.520	1.000	4-7/8	4

\* Subject to quote

**Explanation of pilot sizes for all Craig Port Contour cutters.** On plain pilot tools, pilot diameter size is based upon piloting in the proper hole. This hole, in order to meet applicable Mil. Spec. should be sized according to the mean of the min-max tolerance on the minor diameter of the specifications. The common practice of using a standard drill without reaming and/or referring to tap drill charts, cannot be followed since, in most cases, there are no standard drills which produce holes sizes that will meet the Mil. Spec. tolerance on minor diameters.



# 49R SERIES

## A.N.D. 10050 & MS 33649 PORT CONTOUR CUTTERS

Carbide tipped, integral reamer pilot, short series

**49R SERIES** carbide port tools profile the A.N.D. 10050 or MS33649 contour. While the tools are form relieved to provide cutting of the complete form and ream diameter on all four flutes, the shorter body permits rugged construction with greater economy. These tools have one piece carbide tips and all grinding is done between centers to insure concentricity.

Modifications of standard tools are readily available. Special cutters, manufactured to customer's specifications, are given prompt attention.

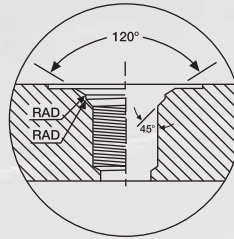
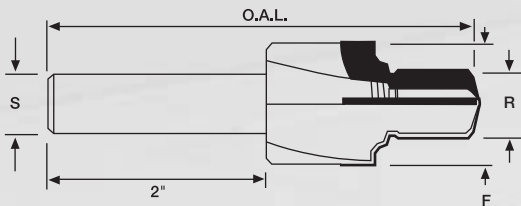
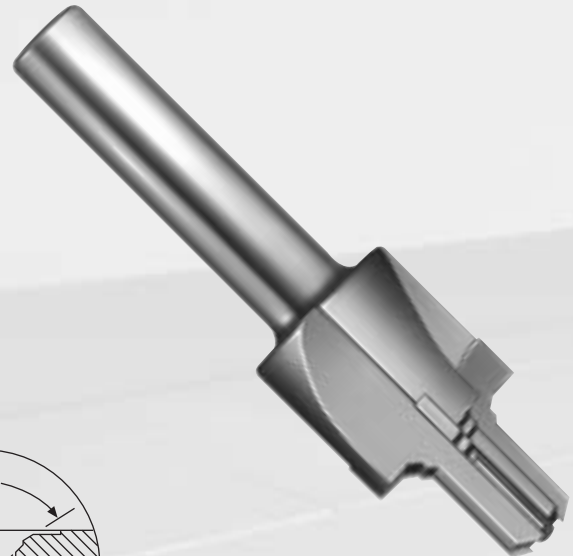

TOOL NUMBER	TUBING O.D.	THREAD SIZE	"PILOT DIAMETER"		"F" SPOTFACE DIAMETER	"S" SHANK DIAMETER	"O.A.L." OVERALL LENGTH	NUMBER OF FLUTES
			A.N.D. 10050	M.S. 33649				
49R-2	1/8	5/16-24	.271	.275	.742	.500	3-19/32	3
49R-3	3/16	3/8-24	.333	.339	.805	.500	3-19/32	3
49R-4	1/4	7/16-20	.386	.393	.888	.500	3-21/32	4
49R-5	5/16	1/2-20	.449	.455	.950	.500	3-21/32	4
49R-6	3/8	9/16-18	.506	.512	1.012	.500	3-11/16	4
49R-7*	7/16	5/8-18	—	.575	1.105	.500	3-15/16	4
49R-8	1/2	3/4-16	.687	.693	1.240	.500	3-15/16	4
49R-9*	9/16	13/16-16	—	.756	1.302	.750	4-7/32	4
49R-10	5/8	7/8-14	.802	.810	1.415	.750	4-7/32	4
49R-11*	11/16	1-12	—	.925	1.602	.750	4-1/2	4
49R-12	3/4	1-1/16-12	.976	.987	1.665	.750	4-1/2	4
49R-14*	7/8	1-3/16-12	—	1.112	1.790	.750	4-1/2	4
49R-16	1	1-5/16-12	1.226	1.237	1.965	.750	4-1/2	4
49R-18*	1-1/8	1-1/2-12	—	1.425	2.090	.750	4-9/16	4
49R-20*	1-1/4	1-5/8-12	1.538	1.550	2.310	.750	4-9/16	4
49R-24*	1-1/2	1-7/8-12	1.788	1.800	2.600	.750	4-11/16	4
49R-28*	1-3/4	2-1/4-12	2.163	2.175	3.050	1.000	5	4
49R-32*	2	2-1/2-12	2.414	2.425	3.520	1.000	5-1/8	4

\* Subject to quote

**Explanation of pilot sizes for all Craig Port Contour cutters.** On plain pilot tools, pilot diameter size is based upon piloting in the proper hole. This hole, in order to meet applicable Mil. Spec. should be sized according to the mean of the min-max tolerance on the minor diameter of the specifications. The common practice of using a standard drill without reaming and/or referring to tap drill charts, cannot be followed since, in most cases, there are no standard drills which produce holes sizes that will meet the Mil. Spec. tolerance on minor diameters.



## S.A.E. STRAIGHT THREAD TUBE FITTING (MS 16142) PORT CONTOUR CUTTERS

High speed steel, integral plain pilot

**H42P SERIES** port tools profile the internal O-ring boss and port contour for the S.A.E. straight thread tube fitting (identical to MS 16142). One operation forms the complete port accurately to military specifications. This high speed steel, short, sturdy cutter performs well in both ferrous and non-ferrous materials and may be used in a wide range of machinery and equipment (such as drill presses, lighter equipment, older machines, etc.), which are not suitable for carbide's high rigidity and high horse-power requirements.

Precision ground between centers to insure concentricity. All cutting edges are form relieved and all flutes cut the entire form to provide balance, distribution of chip load, maximum tool life between grinds, and ease of sharpening.

Modifications of standard tools are readily available. Special cutters, manufactured to customers' specifications, are given prompt attention.

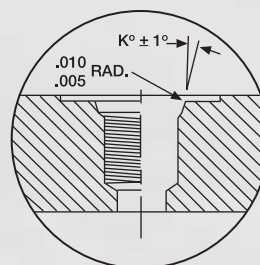
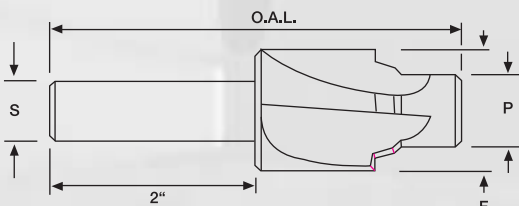

TOOL NUMBER	TUBING O.D.	THREAD SIZE	"P" PILOT DIAMETER	"F" SPOTFACE DIAMETER	"S" SHANK DIAMETER	"K" ANGLE	"O.A.L." OVERALL LENGTH	NUMBER OF FLUTES
H42P-2	1/8	5/16-24	.270	.692	.500	12°	3-7/16	3
H42P-3	3/16	3/8-24	.332	.770	.500	12°	3-7/16	3
H42P-4	1/4	7/16-20	.385	.848	.500	12°	3-1/2	3
H42P-5	5/16	1/2-20	.448	.926	.500	12°	3-1/2	4
H42P-6	3/8	9/16-18	.505	.989	.500	12°	3-23/32	4
H42P-8	1/2	3/4-16	.686	1.208	.500	15°	3-25/32	4
H42P-10	5/8	7/8-14	.801	1.364	.750	15°	3-31/32	4
H42P-12	3/4	1-1/16-12	.975	1.645	.750	15°	4	4
H42P-14	7/8	1-3/16-12	1.096	1.785	.750	15°	4	4
H42P-16	1	1-5/16-12	1.225	1.930	.750	15°	4	4
H42P-20*	1-1/4	1-5/8-12	1.537	2.290	1.000	15°	4	4
H42P-24*	1-1/2	1-7/8-12	1.787	2.580	1.000	15°	4	4
H42P-32*	2	2-1/2-12	2.413	3.500	1.000	15°	4-1/8	4

\* Subject to quote





# H42R SERIES

## S.A.E. STRAIGHT THREAD TUBE FITTING (MS 16142) PORT CONTOUR CUTTERS

High speed steel, integral reamer pilot



**H42R SERIES** port tools are manufactured with an integral reamer pilot (rather than a plain pilot) which sizes the minor diameter of the Class 2 thread specification. They profile the internal O-ring boss and port contour for the S.A.E. straight thread tube fitting (identical to MS16142). One operation forms the complete port accurately to military specifications. This high speed steel, short, sturdy cutter performs well in both ferrous and non-ferrous materials and may be used in a wide range of machinery and equipment (such as drill presses, lighter equipment, older machines, etc.), which are not suitable for carbide's high rigidity and high horsepower requirements.

Precision ground between centers to insure concentricity. All cutting edges are form relieved and all flutes cut the entire form to provide balance, distribution of chip load, maximum tool life between grinds, and ease of sharpening.

Modifications of standard tools are readily available. Special cutters, manufactured to customers' specifications, are given prompt attention.

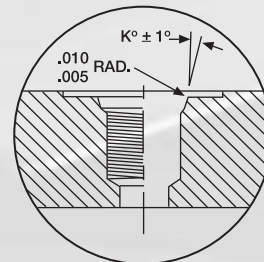
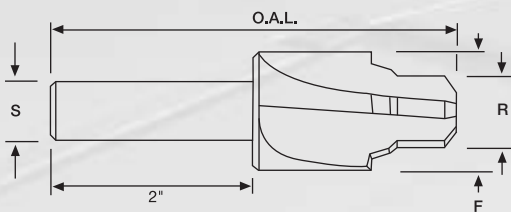

TOOL NUMBER	TUBING O.D.	THREAD SIZE	"P" PILOT DIAMETER	"F" SPOTFACE DIAMETER	"S" SHANK DIAMETER	"K" ANGLE	"O.A.L." OVERALL LENGTH	NUMBER OF FLUTES
H42R-2	1/8	5/16-24	.271	.692	.500	12°	3-5/16	3
H42R-3	3/16	3/8-24	.333	.770	.500	12°	3-9/16	3
H42R-4	1/4	7/16-20	.386	.848	.500	12°	3-5/8	3
H42R-5	5/16	1/2-20	.449	.926	.500	12°	3-5/8	4
H42R-6	3/8	9/16-18	.506	.989	.500	12°	3-13/16	4
H42R-8	1/2	3/4-16	.687	1.208	.500	15°	3-29/32	4
H42R-10	5/8	7/8-14	.802	1.364	.750	15°	4-9/64	4
H42R-12	3/4	1-1/16-12	.976	1.645	.750	15°	4-1/4	4
H42R-14	7/8	1-3/16-12	1.097	1.785	.750	15°	4-9/32	4
H42R-16	1	1-5/16-12	1.226	1.930	.750	15°	4-9/32	4
H42R-20*	1-1/4	1-5/8-12	1.538	2.290	1.000	15°	4-5/16	4
H42R-24*	1-1/2	1-7/8-12	1.788	2.580	1.000	15°	4-5/16	4
H42R-32*	2	2-1/2-12	2.414	3.500	1.000	15°	4-11/32	4

\* Subject to quote



## S.A.E. STRAIGHT THREAD TUBE FITTING (MS 16142) PORT CONTOUR CUTTERS

Carbide tipped, integral plain pilot

**42P SERIES** port tools profile the internal O-ring boss and port contour for the S.A.E. straight thread tube fitting (identical to MS 16142).

Modifications of standard tools are readily available. Special cutters, manufactured to customers' specifications, are given prompt attention.

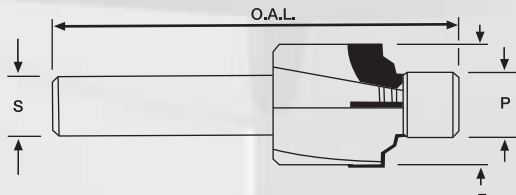
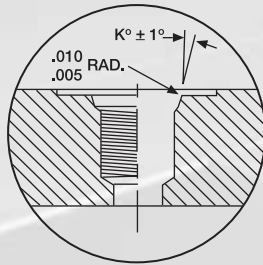

TOOL NUMBER	TUBING O.D.	THREAD SIZE	"P" PILOT DIAMETER	"F" SPOTFACE DIAMETER	"S" SHANK DIAMETER	"K" ANGLE	"O.A.L." OVERALL LENGTH
42P-2	1/8	5/16-24	.270	.692	.500	12°	3-23/32
42P-3	3/16	3/8-24	.332	.770	.500	12°	3-25/32
42P-4	1/4	7/16-20	.385	.848	.500	12°	3-25/32
42P-5	5/16	1/2-20	.448	.926	.500	12°	3-27/32
42P-6	3/8	9/16-18	.505	.989	.500	12°	3-29/32
42P-8	1/2	3/4-16	.686	1.208	.500	15°	3-31/32
42P-10	5/8	7/8-14	.801	1.364	.750	15°	3-31/32
42P-12	3/4	1-1/16-12	.975	1.645	.750	15°	4-1/8
42P-14	7/8	1-3/16-12	1.096	1.785	.750	15°	4-1/8
42P-16	1	1-5/16-12	1.225	1.930	.750	15°	4-1/8
42P-20*	1-1/4	1-5/8-12	1.537	2.290	1.000	15°	4-1/8
42P-24*	1-1/2	1-7/8-12	1.787	2.580	1.000	15°	4-1/8
42P-32*	2	2-1/2-12	2.413	3.500	1.000	15°	4-1/4

\* Subject to quote



# 42R SERIES

## S.A.E. STRAIGHT THREAD TUBE FITTING (MS 16142) PORT CONTOUR CUTTERS

Carbide tipped, integral reamer pilot

**42R SERIES** port tools are identical to the 42P Series cutters except that they are manufactured with an integral carbide tipped reamer pilot (rather than a plain pilot) which sizes the minor diameter of the Class 2 thread specifications.

Modifications of standard tools are readily available. Special cutters, manufactured to customers' specifications, are given prompt attention.

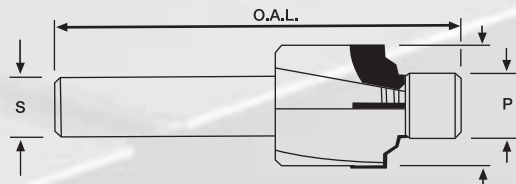
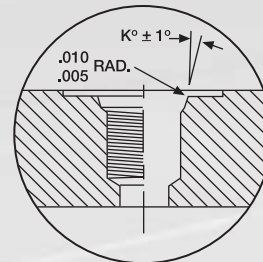

TOOL NUMBER	TUBING O.D.	THREAD SIZE	"P" PILOT DIAMETER	"F" SPOTFACE DIAMETER	"S" SHANK DIAMETER	"K" ANGLE	"O.A.L." OVERALL LENGTH
42R-2	1/8	5/16-24	.271	.692	.500	12°	3-23/32
42R-3	3/16	3/8-24	.333	.770	.500	12°	3-25/32
42R-4	1/4	7/16-20	.386	.848	.500	12°	3-25/32
42R-5	5/16	1/2-20	.449	.926	.500	12°	3-27/32
42R-6	3/8	9/16-18	.506	.989	.500	12°	3-29/32
42R-8	1/2	3/4-16	.687	1.208	.500	15°	3-21/32
42R-10	5/8	7/8-14	.802	1.364	.750	15°	3-31/32
42R-12	3/4	1-1/16-12	.976	1.645	.750	15°	4-1/8
42R-14	7/8	1-3/16-12	1.097	1.785	.750	15°	4-1/8
42R-16	1	1-5/16-12	1.2265	1.930	.750	15°	4-1/8
42R-20*	1-1/4	1-5/8-12	1.538	2.290	1.000	15°	4-1/8
42R-24*	1-1/2	1-7/8-12	1.788	2.580	1.000	15°	4-1/8
42R-32*	2	2-1/2-12	2.414	3.500	1.000	15°	4-1/4

\* Subject to quote





## NOTES





## CRAIG TOOLS INTERNATIONAL

USA

142 Lomita Street, PO Box 747  
El Segundo, California 90245 USA  
(310) 322-0614 Fax (310) 615-0455

[www.craigtools.com](http://www.craigtools.com)

Catalog S • Copyright 2008

Member



## CRAIG TOOLS INTERNATIONAL

UK AND EUROPE

Unit 6

Riding Court, Riding Road  
Buckingham Road Industrial Estate, Brackley  
Northants England

NN13 7BH

Tel +44 (0) 1280-700101

Fax +44 (0) 1280-700644